

HITACHI SWITCHES

(UP TO AC 660V)

Magnetic starters and contactors
Automatic star-delta starters

Thermal overload relays
K-Type manual starters

Contactor relays
Push buttons

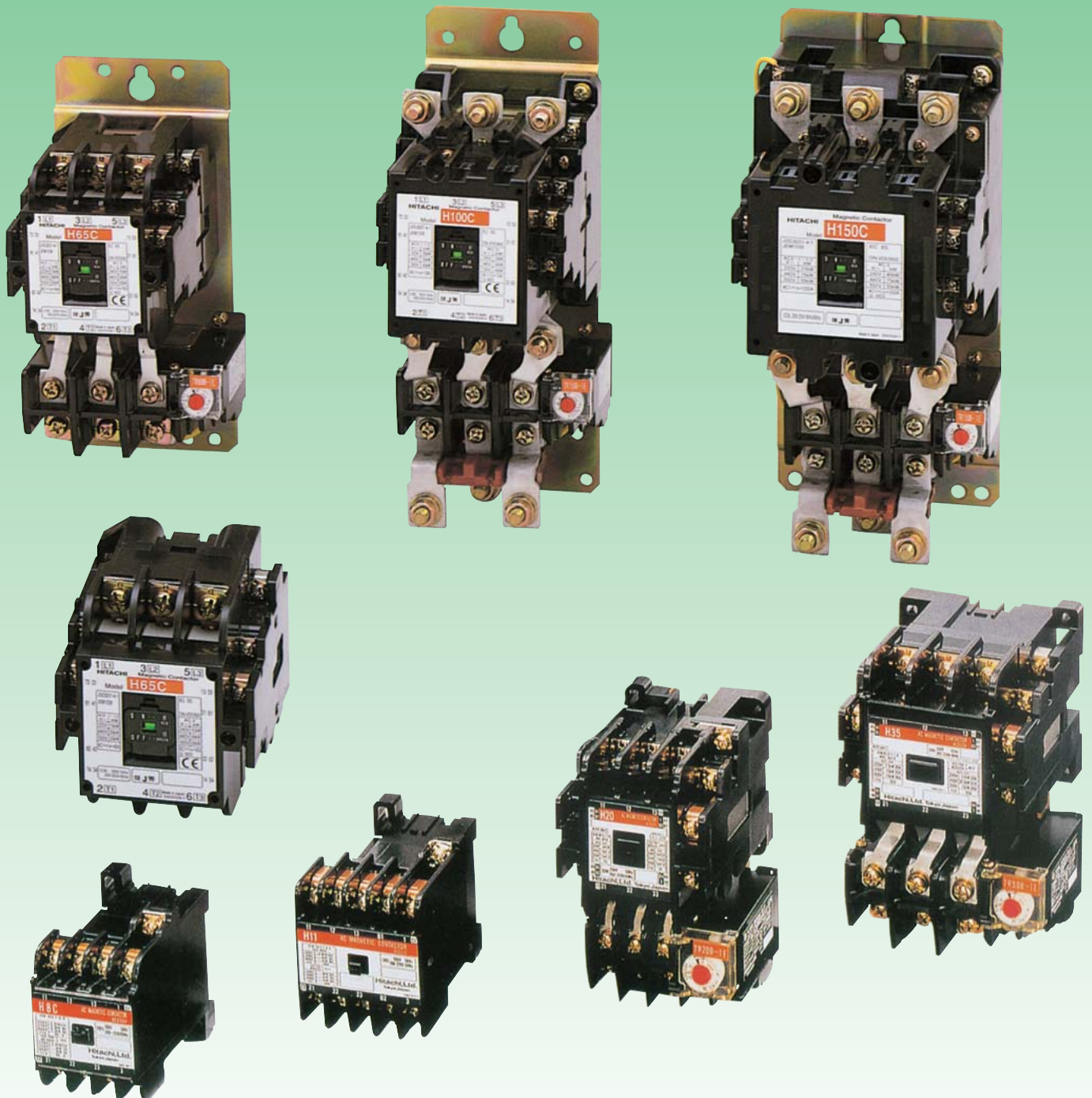





CONTENTS

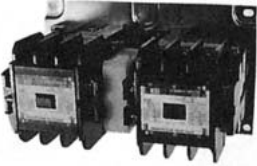
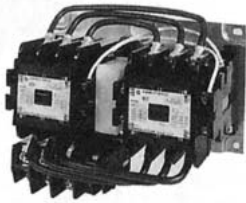

MAGNETIC STARTERS AND CONTACTORS	2
1. TYPES AND MODEL ARRANGEMENTS OF ELECTROMAGNETIC STARTERS AND CONTACTORS	2
2. FEATURES OF STANDARD TYPE ELECTROMAGNETIC STARTERS AND CONTACTORS	3
3. CONSTRUCTION	6
4. RATINGS AND SPECIFICATIONS	7
4-1 Standard Models	7
4-2 Thermal Overload Relays	9
4-3 Electromagnetic Starters with 2E Thermal Overload Relay	11
4-4 DC Operated Electromagnetic Contactors	13
4-5 Latched Electromagnetic Contactors	15
4-6 Contact or Relays	17
5. STANDARD TYPE ELECTROMAGNETIC STARTERS AND CONTACTORS	19
5-1 Coil Specifications	19
5-2 Performance	19
5-3 Application for the International Standards	19
5-4 Normal Service Conditions	19
5-5 Selection	20
5-6 Cautions	22
5-7 Appearance and Dimensions	23
6. THERMAL OVERLOAD RELAYS	31
6-1 Features	31
6-2 Construction	31
6-3 Tripping Characteristics	32
6-4 Application	33
6-5 Appearance and Dimensions	35
7. ELECTROMAGNETIC STARTERS WITH 2E THERMAL OVERLOAD RELAY (OVERLOAD AND PHASE-FAILURE PROTECTION)	37
7-1 Phase-Failure Protection Effect of 2E Thermal Overload Relays	37
7-2 Appearance and Dimensions	37
8. DC OPERATED ELECTROMAGNETIC CONTACTORS	38
8-1 Operating Principle of Double Coil	38
8-2 Dimensions	38
9. LATCHED ELECTROMAGNETIC CONTACTORS	39
9-1 Explanation of Operation	39
9-2 Dimensions	39
10. AUTOMATIC STAR-DELTA STARTERS (3-CONTACTORS TYPE)	41
10-1 Ratings and Specifications	41
10-2 Connection Diagram	42
10-3 Dimensions	42
11. CONTACTOR RELAYS	43
11-1 Application for the International Standards	43
11-2 Return Spring Classification According to Contact Arrangement	43
11-3 Coil Ratings	43
11-4 Contact Arrangement Diagram	44
11-5 Dimensions and Weight	44
12. OPTIONS	45
12-1 Aux. Contact Block, Lamp Unit, Safety Cover and Mechanical Interlock Unit	45
12-2 Coil Surge Absorber	46
13. MAINTENANCE	47
K-TYPE MANUAL STARTERS	49
PUSH BUTTONS (FOR OPERATING OF MAGNETIC STARTERS AND CONTACTORS)	50

MAGNETIC STARTERS AND CONTACTORS

1. TYPES AND MODEL ARRANGEMENTS OF ELECTROMAGNETIC STARTERS AND CONTACTORS

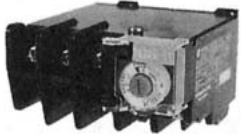
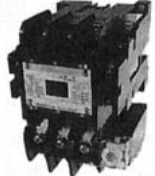
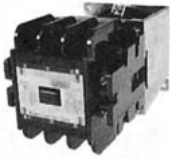
	Electromagnetic Contactors	Electromagnetic Starters	
		Without Enclosure	With Enclosure
Non-reversible Type	H□	H□-T	SH□-T
			
	8C-800C frame	8C-600C frame	8C-600C frame
Reversible Type [20 ~ 800C frame (:provided mechanical interlock)	H□-R	H□-RT	SH□-RT
			
	10B-800C frame	10B-600C frame	10B-600C frame

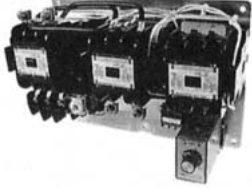
Thermal Overload Relays	Electromagnetic Starters with 2E Thermal Overload Relay	DC Operated Electromagnetic Contactors
TR□ (1E/2E)	H) □ - (TK/RTK SH)	H□-G
		
12B-600B	8C-600C frame	10 ~ 800C frame

Latched Contactors	Automatic Star-delta Starters	Contactors Relays
H□-L	(S)Y □ (S)Y4 - □	X□
		
10 ~ 600C frame	200V class: 5-75 frame 400V class: 11-110 frame	3 contacts - 8 contacts

2. FEATURES OF STANDARD TYPE ELECTROMAGNETIC STARTERS AND CONTACTORS

NEW C-SERIES LINE-UP (65A TO 800A FRAME)

International standards approval.

Conforms to IEC 60947-4-1, BS, DIN and VDE standards (H65C to H800C). Adapt to CE-Marking (H65C to H125C).

Applicable to use for crane and hoist due to shortened breaking time of contactors.

EASILY CERTAIN THE OPERATION BY COLOR INDICATOR

New color-indicators enable certain discrimination of moving.

Contactors

Color of indicator changes from green to red after the contactor is closed (H65C ~ H800C).

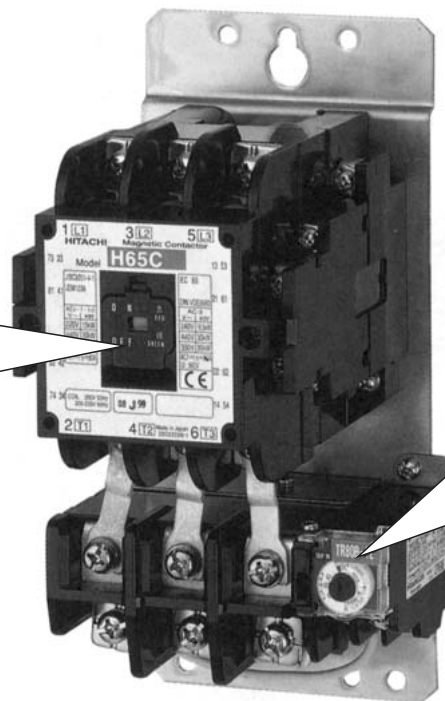
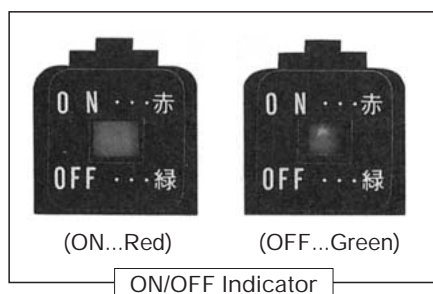

Thermal overload relays

Color of indicator changes from black to yellow if the thermal overload relay was tripped (All models).

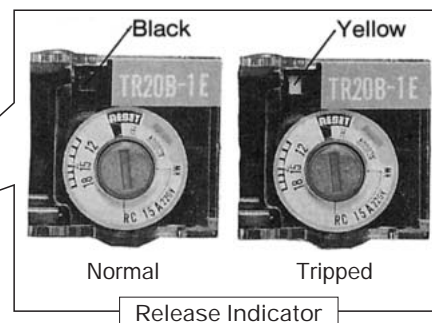

NOISELESS ELECTRO-MAGNET COIL

Electromats excited on DC will not permit buzzing (H150C to H800C).



Stop buzzing

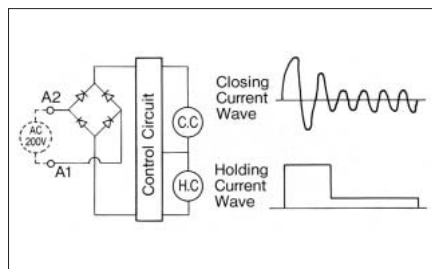

Built-in coil surge absorber

Built-in coil surge absorber prevents generation of surge voltage.

Voltage drop

Even if the operating voltage suddenly drops 65% of the rated voltage of contactors, contactors certainly keep on position without chattering.

HIGH SAFETY

New preventive mechanism for mal-operation, phase separator, etc.

Preventive mechanism of careless operation

• Contactors
Sequence check rod will be operated when the indicator is opened (H65C ~ H800C).

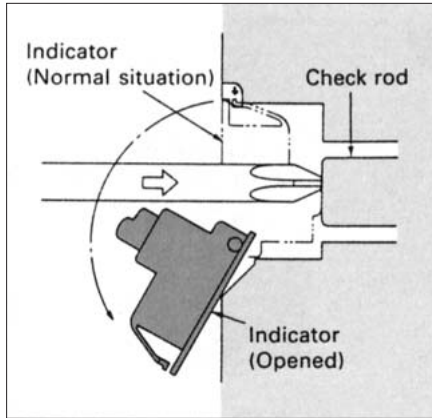

• Thermal overload relays "Cover" prevents the touch to release test lever (All models).

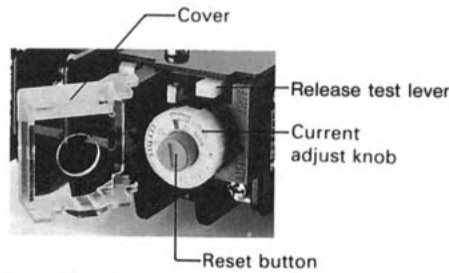

Free arc space

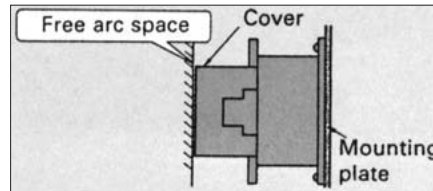

Phase separator

Additional phase separator (H80C ~ H800C).
Phase separators will be attached to the contactor.

Mechanical interlock

(Reversible type: over H20)
Mechanical interlock is also attached to reversible contactor.

Safety cover (option)

Easy attachment (H8C ~ H800C).
Live parts will be covered by safety cover, and it improves safety.

HIGH RELIABILITY

Highly reliable contacts enable direct connection to the electronic circuits.

Auxiliary contacts of contactors

Rolling twin contacts assure high contact reliability (All models).

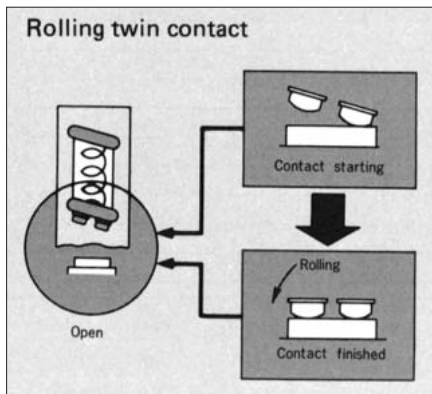

Signal contacts of thermal overload relays

Signal contacts of thermal overload relays are 1NO 1NC (All models).

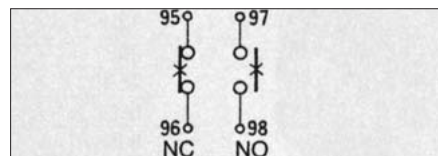

Auxiliary contact block (H20 ~ H400C)

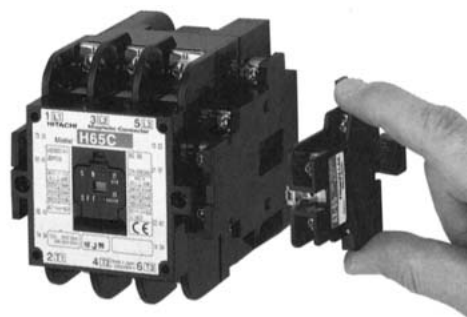

Coil surge absorber

Coil surge absorber will be installed by "Single Snap Action" (H8C ~ H125C), and For H150C and above, it is constructed in coil assembly.

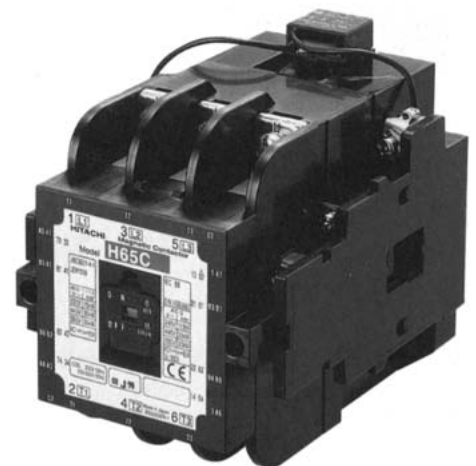

EASY MAINTENANCE AND INSPECTION

Quick contact inspection

Access to contacts is done by unfastening two screws and removing the cover.

Easy contact replacement

Contact can be removed/replaced by single snap action without taking off the contact spring (H80C ~ H400C).

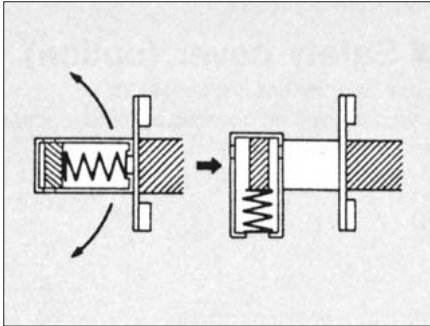

Easy wiring

- Adoption of washer-based self-up screw.
Main terminal screw: up to H65C.
Operation terminal screw: all models.
- Flat terminals built-in rugged studs facilitate connection of wires with a single spanner (H100C ~ H600C).

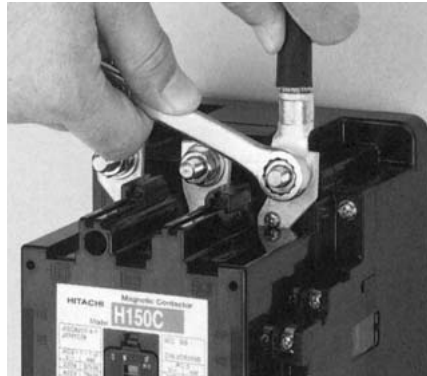

DIN rail mounting mechanism

H8C ~ H50 are available DIN rail mounting.

Front indication of nameplate



THERMAL OVERLOAD RELAYS

Plentiful products enable easy selection of motor protection.

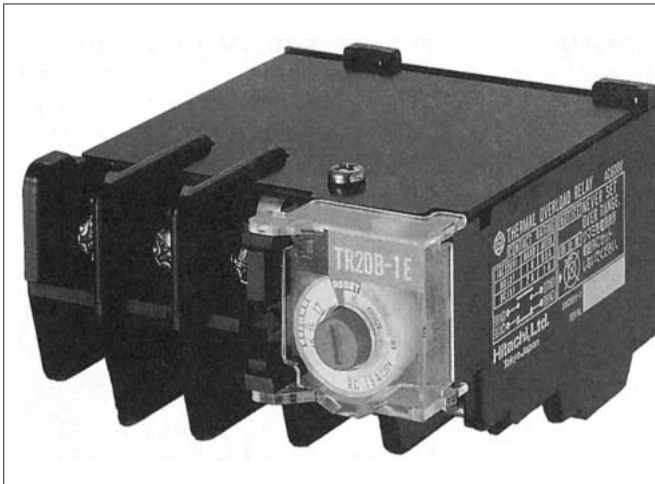

FRAME	CATEGORY	Standard relay with overload protection (1E)	Relay with overload and single phasing protection (2E)
12B			
20B			
25B			
50B			
80B			
150B			
250B			
400B			
600B			

Optional accessories

- Reset release...12B, 20B ~ 600B
- Trip indicating lamp...12B ~ 600B
- Safety cover...20B, 50B, 80B (except with CT)

Numbers of Heat Elements

- 1E...normally 2 Heat Elements. 3 Heat Elements type is also available as option.
- 2E...3 Heat Elements.

IEC STANDARD

Contactors and thermal overload relays conform to the IEC standard.

3. CONSTRUCTION

Small and medium capacity models

EXAMPLE: H35

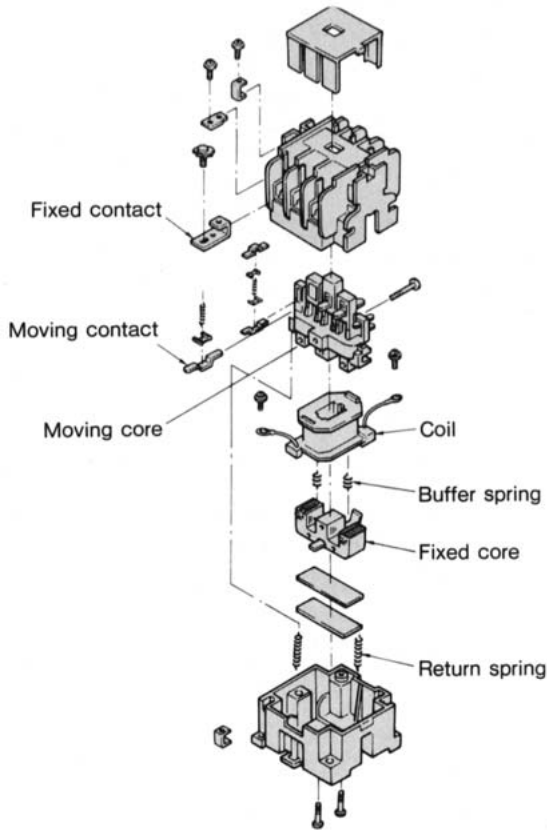

BUFFER SPRING

The smaller the contact bounce of the electromagnetic contactor, the longer the life. The electromagnetic contactor is so constructed that the movement of the core is directly changed into the movement of the contact. Due to this, the shock of the core is directly linked to the bounce of the contact. An optimum buffer spring has been adopted to relieve the core shock.

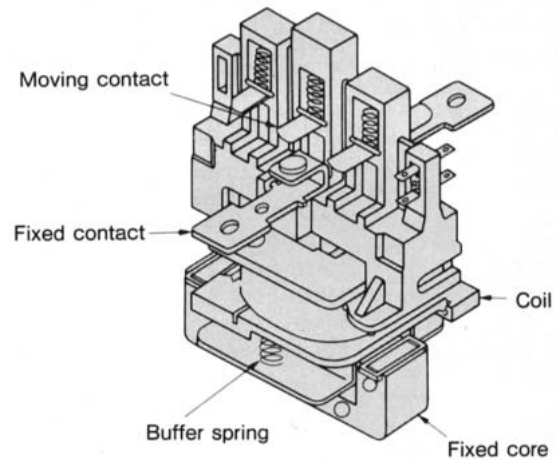

TWIN CONTACT

Twin contact is provided for each auxiliary contact of H8C-H800C. The contact points of Twin contact becomes twice in comparison with Single contact.

In case of Single contact, accordingly, if incomplete contact occurred at A or B, the circuit was opened, however in case of Twin contact, the circuit loses continuity after incomplete contact occurs at both A1 and A2 or B1 and B2. i.e. Twin contact has higher contact reliability than Single contact. Min. rating current of Twin contact is 10mA 24V instead of 10mA at 48V for Single contact.

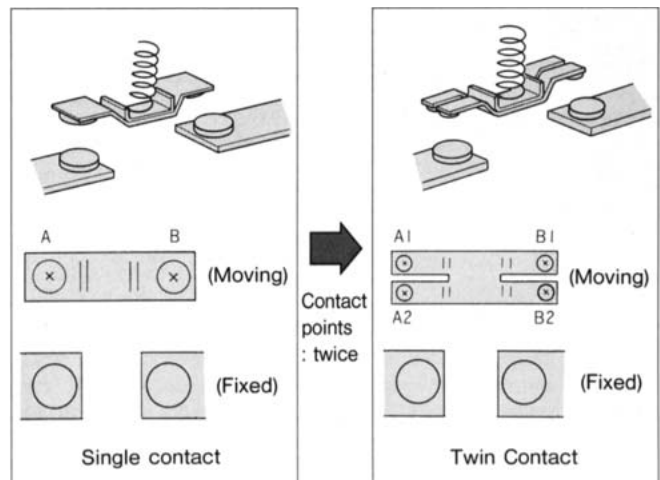

4. RATINGS AND SPECIFICATIONS

4.1 Standard Models

Item			Frame																																					
			8C	10C	10B	11	12	20	25	35		50	65C	80C	100C	125C	150C	200C	250C	300C	400C	600C	800C																	
Type	Electromagnetic contactor without enclosure	Non-reversible	H8C	H10C		H11	H12	H20	H25	H35		H50	H65C	H80C	H100C	H125C	H150C	H200C	H250C	H300C	H400C	H600C	H800C																	
		Reversible			H10B-R	H11-R	H12-R	H20-R	H25-R	H35-R		H50-R	H65C-R	H80C-R	H100C-R	H125C-R	H150C-R	H200C-R	H250C-R	H300C-R	H400C-R	H600C-R	H800C-R																	
	Electromagnetic starter	Without enclosure	Non-reversible	B) H8C-T	B) H10C-T		B) H11-T	B) H12-T	B) H20-T	B) H25-T	B) H35-T		B) H50-T	B) H65C-T	B) H80C-T	B) H100C-T	B) H125C-T	B) H150C-T	B) H200C-T	B) H250C-T	B) H300C-T	B) H400C-T	B) H600C-T																	
		With enclosure	Non-reversible	B) SH8C-T	B) SH10C-T		B) SH11-T		B) SH20-T	B) SH25-T	B) SH35-T		B) SH50-T	B) SH65C-T	B) SH80C-T	B) SH100C-T	B) SH125C-T	B) SH150C-T	B) SH200C-T	B) SH250C-T	B) SH300C-T	B) SH400C-T	B) SH600C-T																	
			Reversible			B) SH10B-RT	B) SH11-RT		B) SH20-RT	B) SH25-RT	B) SH35-RT		B) SH50-RT	B) SH65C-RT	B) SH80C-RT	B) SH100C-RT	B) SH125C-RT	B) SH150C-RT	B) SH200C-RT	B) SH250C-RT	B) SH300C-RT	B) SH400C-RT	B) SH600C-RT																	
	Thermal overload relay				TR12B-1E			TR20B-1E	TR25B-1E	TR50B-1E		TR50B-1E	TR80B-1E		TR150B-1E		TR250B-1E		TR400B-1E	TR600B-1E																				
Rated insulation	voltage		AC 660V												AC 660V																									
Max. rated capacity of motor	JIS C8201-4-1 and JEM1038	Rated operational current (A) AC3	200 ~ 220V	11	12	12	12	20(18)	26	35		50(48)	65	80	100	125	150	180	240	300	400	600	800(AC2)																	
			380 ~ 440V	6	9	9	9	17	24	32		47	65	80	100	125	150	180	240	300	400	600	800(AC2)																	
			500 ~ 550V	5	8	6	8	12	12	26		37	52	72	72	72	80	145	145	250	350	500																		
		Three-phase motor (kW) AC3 and AC2	200 ~ 220V	2.2	2.5	2.5	2.5	4(3.7)	5.5	7.5		11	15	19	25	30	37	45	60	75	110	150	200	300																
			380 ~ 440V	2.2	4	4	4	7.5	11	15		22	30	37	50	60	75	90	120	150	200	300	400(AC2)																	
		500 ~ 550V	2.2	4	3.7	4	7.5	7.5	15		22	30	45	45	45	55	90	90	160	200	300																			
	IEC 60947-4-1	Rated operational current (A) AC3	220 ~ 240V	11	12	12	12	22(20)	27	39		52(48)	65	80	105	126	150	182	240	300	400	600	800(AC2)																	
			380 ~ 440V	7	9	9	9	22(20)	24	37		47	65	80	100	125	150	180	240	300	400	600	800(AC2)																	
			500 ~ 550V	5	8	6	8	12	12	26		37	52	72	72	72	80	145	145	250	350	500																		
		Three-phase motor (kW) AC3	220 ~ 240V	2.5	3	3	3	5.5	*7.5	11		15(11)	18.5	22	30	37	45	55	75	90	115	160	200(AC2)																	
		380 ~ 440V	3	4	4	4	11	11	18.5		22	30	37	50	60	75	90	120	150	200	300	400(AC2)																		
	500 ~ 550V	3	4	3.7	4	7.5	7.5	15		22	30	45	45	45	55	90	90	160	200	300																				
Single-phase motor (kW) AC3 JIS, JEM and IEC		100 ~ 110V	0.4	0.4		0.4	0.75																																	
		200 ~ 220V	0.75	0.75		0.75																																		
	Inching (kW) AC4 (Inching ratio 50%, electrical life 0.1 million times) JIS, JEM and IEC	200 ~ 240V	0.75	1.5	1.5	1.5	2.2	3.7	5.5		7.5	9	13	13	15	22	30	37	45	55	75																			
	380 ~ 440V	1.5	2.2	2.2	2.2	3.7	5.5	7.5		11	15	19	19	22	30	37	45	55	55	75																				
Rated capacity for resistance load (A) AC1 (Electrical life 0.5 million times) JIS, JEM and IEC		200 ~ 240V	20	20	18	20	32	35	50		70	80	120	135	150	200	260	300	350	420	600	800 (0.1million times)																		
		380 ~ 440V	20	20	18	20	32	35	50		70	80	120	135	150	200	260	300	350	420	600	800 (0.1million times)																		
Rated thermal current (Ith) A	Without enclosure	200 ~ 240V	20	20	18	20	32	35	50		70	80	120	135	150	200	260	300	350	420	600	800																		
	With enclosure	200 ~ 240V	15	15	15	15	26	35	44		60	65	80	105	125	150	180	240	300	400	600	800																		
Characteristics of operation coil	Coil burden (max.) (VA) 50/60Hz	Pick-up	45/40			45/40			90/80			165/150			165/150			220/190			490/420			400/400			480/480			1600/1600			1800/1800							
		Hold-in	9/7			9/7			14/11			16/12			16/12			18/14			50/40			8/8			9/9			10/10			14/14							
	Coil consumption (W) (mean)	2.4			2.4			2.4			3.5			4.5			4.5			6			9.5			7			8			8			13					
	Pick-up voltage (% of rated voltage) (mean)	65			75			68			75			68			73			73			75			75			70			70			70			70		
	Drop-out voltage (% of rated voltage) (mean)	50			50			50			50			53			53			53			58			58			45			45			35			35		
Operating time (ms) (reference value)	Pick-up	10 ~ 15			10 ~ 15			10 ~ 15			10 ~ 20			10 ~ 20			10 ~ 20			10 ~ 20			10 ~ 25			30 ~ 50			30 ~ 50			35 ~ 60			40 ~ 70					
	Drop-out	10 ~ 30			10 ~ 30			10 ~ 30			10 ~ 35			10 ~ 25			10 ~ 25			10 ~ 25			10 ~ 30			10 ~ 30			20 ~ 40			20 ~ 45			20 ~ 45			25 ~ 50		
Auxiliary contact specification	Number	Standard	1NO or 1NC			(2NO1NC)			1NO1NC or 2NO2NC			2NO1NC or 1NO2NC			1NO1NC			2NO2NC			2NO2NC			4NO4NC(3NO3NC...Reversible)			4NO4NC													
		Maximum	1NO or 1NC			(2NO1NC) × 2			2NO2NC			1NO2NC			1NO1NC			2NO2NC			2NO2NC			4NO4NC(3NO3NC...Reversible)			4NO4NC													
	Rated operational current (A)	200 ~ 240V			200 ~ 240V			200 ~ 240V			200 ~ 240V			200 ~ 240V			200 ~ 240V			200 ~ 240V			200 ~ 240V			200 ~ 240V			200 ~ 240V			200 ~ 240V								
Rated thermal current (A)	10(Twin contact)			10(Twin contact)			10(Twin contact)			10(Twin contact)			10(Twin contact)			10(Twin contact)			10(Twin contact)			10(Twin contact)			10(Twin contact)			10(Twin contact)			10(Twin contact)			10(Twin contact)						
Application models	With mechanical interlock																																							
	With 2E thermal overload relay																																							
	With three-element thermal overload relay																																							
	With latch				(H10-L)																																			
	DC operation				(H10-G)																																			
DIN rail mounting																																								

Notes:

- The ratings of the 200V class in the parenthesis when frames 20 and 50 are provided with an enclosure.
- The rated thermal current applies to electromagnetic contactors.
- The pick-up and drop-out voltages apply to 200V 60Hz power source. In case of 50Hz, the figures for frame 8C ~ 125C are about 10% smaller and for frame 150C ~ 800C are about the same.
- Application of Category AC3 and AC2 to the reversible electromagnetic contactors and starters shall be limited to regular reversible operation in which a motor starts reverse rotation after it has once stopped. Category AC4 is applicable when the motor starts reverse rotation before it has completely stopped.
- The mark () in the application indicates that they are standard.
- Operating time is a reference value where 200V 50Hz is applied to AC

200V coil. Operating time varies with coil voltage, frequency and phase so it is unsuitable for timing use.

- Testing conditions of electrical life (Category AC3): The making and breaking currents and operating frequency of the electrical life are tested as shown in the right drawing according to test conditions of JIS C8201-4-1, JEM 1038 and IEC 60947-4-1.
- *Thermal overload relay for 220 ~ 240V 7.5kW is TR50B-1E.
- The minimum rating of auxiliary contact is 48V 10mA for the single contact and 24V 10mA for the twin contact.

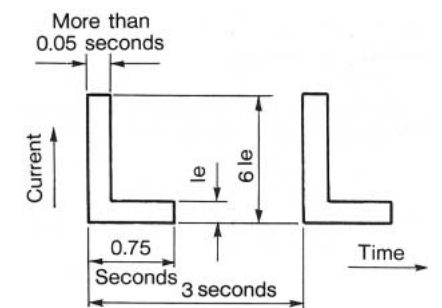

le:Rated operational current

4.3 Electromagnetic Starters with 2E Thermal Overload Relay

Item				Frame								65C	80C	100C	125C	150C	200C	250C	300C	400C	600C				
Type	Electro-magnetic Starter	Without enclosure		B) H8C-TK	B) H10C-TK		B) H11-TK	B) H20-TK	B) H25-TK	B) H35-TK	B) H50-TK		H65C-TK	H80C-TK	H100C-TK	H125C-TK	H150C-TK	H200C-TK	H250C-TK	H300C-TK	H400C-TK	H600C-TK			
		Non-reversible				B) H10B-RTK	B) H11-RTK	B) H20-RTK	B) H25-RTK	B) H35-RTK	B) H50-RTK		H65C-RTK	H80C-RTK	H100C-RTK	H125C-RTK	H150C-RTK	H200C-RTK	H250C-RTK	H300C-RTK	H400C-RTK	H600C-RTK			
		Reversible					B) SH11-TK	B) SH20-TK	B) SH25-TK	B) SH35-TK	B) SH50-TK		SH65C-TK	SH80C-TK	SH100C-TK	SH125C-TK	SH150C-TK	SH200C-TK	SH250C-TK	SH300C-TK	SH400C-TK	SH600C-TK			
		With enclosure				B) SH10B-RTK	B) SH11-RTK	B) SH20-RTK	B) SH25-RTK	B) SH35-RT	B) SH50-RTK		SH65C-RTK	SH80C-RTK	SH100C-RTK	SH125C-RTK	SH150C-RTK	SH200C-RTK	SH250C-RTK	SH300C-RTK	SH400C-RTK	SH600C-RTK			
Thermal overload relay				TR12B-2E				TR20B-2E	TR25B-2E	TR50B-2E		TR80B-2E		TR150B-2E			TR250B-2E		TR400B-2E		TR600B-2E				
Rated insulation voltage				AC 660V											AC 660V										
Max. rated capacity of motor	JIS C8201-4-1 and JEM1038	Rated operational current (A) AC3	200 ~ 220V	11	12	12	12	20 (18)	26	35	50 (48)		65	80	100	125	150	180	240	300	400	600			
			380 ~ 440V	6	9	9	9	17	24	32	47		65	80	100	125	150	180	240	300	400	600			
			500 ~ 550V	5	8	6	8	12	12	26	37		52	72	72	72	80	145	145	250	350	500			
		Three-phase motor (kW) AC3 and AC2	200 ~ 220V	2.2	2.5	2.5	2.5	4 (3.7)	5.5	7.5	11		15	19	25	30	37	45	60	75	110	150			
			380 ~ 440V	2.2	4	4	4	7.5	11	15	22		30	37	50	60	75	90	120	150	200	300			
			500 ~ 550V	2.2	4	3.7	4	7.5	7.5	15	22		30	45	45	45	55	90	90	160	200	300			
	IEC 60947-4-1	Rated operational current (A) AC3	220 ~ 240V	11	12	12	12	22 (20)	27	39	52 (48)		65	80	105	126	150	182	240	300	400	600			
			380 ~ 440V	7	9	9	9	22 (20)	24	37	47		65	80	100	125	150	180	240	300	400	600			
			500 ~ 550V	5	8	6	8	12	12	26	37		52	72	72	72	80	145	145	250	350	500			
		Three-phase motor (kW) AC3	220 ~ 240V	2.5	3	3	3	5.5	7.5	11	15 (11)		18.5	22	30	37	45	55	75	90	115	160			
			380 ~ 440V	3	4	4	4	11	11	18.5	22		30	37	50	60	75	90	120	150	200	300			
			500 ~ 550V	3	4	3.7	4	7.5	7.5	15	22		30	45	45	45	55	90	90	160	200	300			
Characteristics of operation coil	Coil burden (max.) (VA)	Pick-up	45/40		45/40	45/40	90/80		165/150			220/190	490/420			400/400	480/480		1600/1600		1800/1800				
		Hold-in	9/7		9/7	9/7	14/11		16/12			18/14	50/40			8/8	9/9		10/10		14/14				
	Coil consumption (mean) (W)	2.4		2.4	2.4	3.5		4.5			6	9.5			7	8		8		13					
	Pick-up voltage (% of rated voltage)(mean)	65		75	68	68		73			75	75			70	70		70		70					
	Drop-out voltage (% of rated voltage)(mean)	50		50	50	53		53			58	58			45	45		35		35					
	Operating time (ms) 200V, 50Hz(reference value)	Pick-up	10 ~ 15		10 ~ 15	10 ~ 15	10 ~ 20		10 ~ 20			10 ~ 20	10 ~ 25			30 ~ 50	30 ~ 50		35 ~ 60		40 ~ 70				
Drop-out		10 ~ 30		10 ~ 30	10 ~ 30	10 ~ 35		10 ~ 35			10 ~ 30	10 ~ 30			20 ~ 40	20 ~ 45		20 ~ 45		20 ~ 50					
Auxiliary contact	Type of contacts	Twin contact										Twin contact													
	Numbers	Standard		(2NO1NC) × 2		1NO1NC or 2NO, 2NC		1NO1NC		2NO2NC		2NO2NC		2NO2NC		3NO3NC		4NO4NC		4NO4NC					
Mechanical interlock unit		Mechanical		10	5	10	5		5		5		5		5		5		5						
Life (million times)		Electrical		2	1	2		1		1		1		1		1		1		0.5					
Available voltage range of operational coil (V)				24 ~ 550											24 ~ 550			100 ~ 440							

Notes:

1. Rating of Auxiliary Contact

Rated operational current					Rated thermal current	Minimum rating
AC(AC15)			DC L/R 40ms			
200 ~ 220V	380 ~ 440V	500 ~ 550V	48V	110V		
2A	1A	0.75A	0.7A	0.3A	10A	24V 10mA

2. The ratings of Max. rated capacity of motor in the parenthesis are provided with an enclosure.

3. The pick-up and drop-out voltage apply to 200V, 60Hz power source. In case of 50Hz, the figures for frame 8C ~ 125C are about 10% smaller and figures for frame 150C ~ 600C are about the same.

Notes:

- Application of Category AC3 and AC2 to the reversible electromagnetic starters shall be limited to regular reversible operation in which a motor starts reverse rotation after it has once stopped. Category AC4 is applicable when the motor starts reverse rotation before it has completely stopped. And the contactors used for reversible operation, they must be electrically interlocked using by mutual NC auxiliary contacts.
- Since operating time depends on coil voltage, frequency or phase etc., the starters must not be applied for timing use.
- Thermal overload relay for 220 ~ 240V 7.5kW is TR50B-2E.

4.4 DC Operated Electromagnetic Contactors

Item			Frame	10	11	20	25	35	50	65C		80C	100C	125C	150C	200C	250C	300C	400C	600C	800C		
Type				H10-G	H11-G	H20-G	H25-G	H35-G	H50-G	H65C-G		H80C-G	H100C-G	H125C-G	H150C-G	H200C-G	H250C-G	H300C-G	H400C-G	H600C-G	H800C-G		
Rated insulation voltage				AC 660V								AC 660V											
Max. rated capacity of motor	JIS C8201-4-1 and JEM1038	Rated operational current(A) AC3	200 ~ 220V	12	12	20	26	35	50	65		80	100	125	150	180	240	300	400	600	800 (AC2)		
			380 ~ 440V	9	9	17	24	32	47	65		80	100	125	150	180	240	300	400	600	800 (AC2)		
			500 ~ 550V	8	8	12	12	26	37	52		72	72	72	80	145	145	250	350	500			
		Three-phase motor (kW) AC3 and AC2	200 ~ 220V	2.5	2.5	4	5.5	7.5	11	15		19	25	30	37	45	60	75	110	150	200	300	400 (AC2)
			380 ~ 440V	4	4	7.5	11	15	22	30		37	50	60	75	90	120	150	200	300	400 (AC2)		
			500 ~ 550V	4	4	7.5	7.5	15	22	30		45	45	45	55	90	90	160	200	300			
	IEC 60947-4-1	Rated operational current(A) AC3	220 ~ 240V	12	12	22	27	39	52	65		80	105	126	150	182	240	300	400	600	800 (AC2)		
			380 ~ 440V	9	9	22	24	37	47	65		80	100	125	150	180	240	300	400	600	800 (AC2)		
			500 ~ 550V	8	8	12	12	26	37	52		72	72	72	80	145	145	250	350	500			
		Three-phase motor (kW) AC3	220 ~ 240V	3	3	5.5	7.5	11	15	18.5		22	30	37	45	55	75	90	115	160	200	300	400 (AC2)
			380 ~ 440V	4	4	11	11	18.5	22	30		37	50	60	75	90	120	150	200	300	400 (AC2)		
			500 ~ 550V	4	4	7.5	7.5	15	22	30		45	45	45	55	90	90	160	200	300			
Single-phase motor (kW) AC3 JIS, JEM and IEC	100 ~ 110V	0.4	0.4	0.75																			
	200 ~ 220V	0.75	0.75																				
	Inching (kW) AC4 (Inching ratio 50%, electrical life 0.1 million times) JIS, JEM and IEC	200 ~ 240V	1.5	1.5	2.2	3.7	5.5	7.5	9		13	13	13	22	30	37	45	45	55				
Rated capacity for resistance load (A) AC1 (Electrical life 0.5 million times) JIS, JEM and IEC	200 ~ 240V	20	20	32	35	50	70	80		120	135	150	200	260	300	350	420	600	800 (0.1 million times)				
	380 ~ 440V	20	20	32	35	50	70	80		120	135	150	200	260	300	350	420	600	800 (0.1 million times)				
Rated thermal current (Ith) (A)	Without enclosure	20	20	32	35	50	70	80		120	135	150	200	260	300	350	420	600	800				
Type of coil				Direct-input coil								Double coil											
Characteristics of operation coil (at 20°C cold start)	Coil burden (W)	Pick-up		11		15		18		22		300		340		380		1400		1400			
		Hold-in		11		15		18		22		4		6		7		9		12			
	Time constant (ms)	Pick-up		28		45		55		60		16		20		30		45		55			
		Hold-in		28		45		55		60		40		65		85		90		105			
	Pick-up voltage (% of rated voltage)(mean)		55	60	60	55	55	68	70	70	70	70											
	Drop-out voltage (% of rated voltage)(mean)		22	23	17	19	20	20	45	45	35	35											
Operating time DC 100V (ms) (reference value)	Pick-up	25 ~ 30	25 ~ 30	35 ~ 40	40 ~ 45	50 ~ 55	25 ~ 40	30 ~ 40	30 ~ 50	35 ~ 60	35 ~ 60												
	Drop-out	15 ~ 20	10 ~ 15	20 ~ 25	20 ~ 25	20 ~ 25	40 ~ 50	20 ~ 40	20 ~ 45	20 ~ 45	25 ~ 50												
Auxiliary contact				Twin contact								Twin contact											
Numbers	Standard	1NO	1NO1NC	1NO1NC	2NO2NC	2NO1NC	2NO2NC	3NO3NC	4NO4NC														
	Maximum	1NO	1NO1NC	2NO2NC	2NO2NC	4NO3NC	4NO4NC	4NO4NC	4NO4NC														
Life (million times)	Mechanical	10							5					5		1	1						
	Electrical (AC3)	1							1					0.5		0.5	0.1 (AC2)						
Available voltage range of operational coil (V)				24 ~ 220								24 ~ 220				100 ~ 220							

Notes:

1. Rating of Auxiliary Contact

Rated operational current					Rated thermal current	Minimum rating
AC(AC15)			DC L/R 40ms			
200 ~ 220V	380 ~ 440V	500 ~ 550V	48V	110V		
2A	1A	0.75A	0.7A	0.3A	10A	24V 10mA

Notes:

- Since operating time depends on coil voltage etc., the contactor must not be applied for timing use.
- When rectifier is used in the operating power source circuit, DC side must be interrupted.
If AC side of the circuit is interrupted, the drop-out time becomes longer because the rectifier constructs closed circuit with coil.
- As a NC contact (wrap NC contact) of H80C ~ H125C-G is used for changing of coil, available numbers of auxiliary contacts are reduced.
Where marked () and self-holding NO contact is included in the numbers.

4.5 Latched Electromagnetic Contactors

Item		Frame	10	11	20	25	35	50	65C		80C	100C	125C	150C	200C	250C	300C	400C	600C	
Type	AC operation	Non-reversible	H10-L	H11-L	H20-L	H25-L	H35-L	H50-L	H65C-L		H80C-L	H100C-L	H125C-L	H150C-L	H200C-L	H250C-L	H300C-L	H400C-L	H600C-L	
		Reversible		H11-RL	H20-RL	H25-RL	H35-RL	H50-RL	H65C-RL		H80C-RL	H100C-RL	H125C-RL	H150C-RL	H200C-RL	H250C-RL	H300C-RL	H400C-RL	H600C-RL	
	DC operation	Non-reversible	H10-LG	H11-LG	H20-LG	H25-LG	H35-LG	H50-LG	H65C-LG		H80C-LG	H100C-LG	H125C-LG	H150C-LG	H200C-LG	H250C-LG	H300C-LG	H400C-LG	H600C-LG	
		Reversible		H11-RLG	H20-RLG	H25-RLG	H35-RLG	H50-RLG	H65C-RLG		H80C-RLG	H100C-RLG	H125C-RLG	H150C-RLG	H200C-RLG	H250C-RLG	H300C-RLG	H400C-RLG	H600C-RLG	
Rated insulation voltage			AC 660V								AC 660 V									
Max. rated capacity of motor	JIS C8201-4-1 and JEM1038	Rated operational current (A) AC3	200 ~ 220V	12	12	20	26	35	50	65		80	100	125	150	180	240	300	400	600
			380 ~ 440V	9	9	17	24	32	47	65		80	100	125	150	180	240	300	400	600
			500 ~ 550V	8	8	12	12	26	37	52		72	72	72	80	145	145	250	350	500
		Three-phase motor (kW) AC3 and AC2	200 ~ 220V	2.5	2.5	4	5.5	7.5	11	15		19	25	30	37	45	60	75	110	150
			380 ~ 440V	4	4	7.5	11	15	22	30		37	50	60	75	90	120	150	200	300
			500 ~ 550V	4	4	7.5	7.5	15	22	30		45	45	45	55	90	90	160	200	300
	IEC60947-4-1	Rated operational current (A) AC3	220 ~ 240V	12	12	22	27	39	52	65		80	105	126	150	182	240	300	400	600
			380 ~ 440V	9	9	22	24	37	47	65		80	100	125	150	180	240	300	400	600
			500 ~ 550V	8	8	12	12	26	37	52		72	72	72	80	145	145	250	350	500
		Three-phase motor (kW) AC3	220 ~ 240V	3	3	5.5	7.5	11	15	18.5		22	30	37	45	55	75	90	115	160
			380 ~ 440V	4	4	11	11	18.5	22	30		37	50	60	75	90	120	150	200	300
			500 ~ 550V	4	4	7.5	7.5	15	22	30		45	45	45	55	90	90	160	200	300
Single-phase motor (kW) AC3 JIS, JEM and IEC	100 ~ 110V	0.4	0.4	0.75																
	200 ~ 220V	0.75	0.75																	
Rated capacity for resistance load (A) AC1 (Electrical life 0.5 million times) JIS, JEM and IEC	200 ~ 240V	20	20	32	35	50	70	80		120	135	180	200	260	300	350	420	600		
	380 ~ 440V	20	20	32	35	50	70	80		120	135	180	200	260	300	350	420	600		
Rated thermal current (Ith) (A)	Without enclosure	20	20	32	35	50	70	80		120	135	180	200	260	300	350	420	600		
Characteristics of operation coil (at 20 °C cold start)	AC operation	Closing coil	Coil burden (VA)	45		140		165		220	700			400		480		2800		8200
			Operating time (reference value) (ms)	10 ~ 15		15 ~ 25		15 ~ 25		15 ~ 25	15 ~ 30			30 ~ 50		30 ~ 50		20 ~ 40		30 ~ 40
		Tripping coil	Coil burden (VA)	55		130		130		130	350			500		700		400		700
			Operating time (reference value) (ms)	20 ~ 30		20 ~ 30		20 ~ 30		20 ~ 30	20 ~ 30			20 ~ 80		50 ~ 100		30 ~ 40		35 ~ 45
	DC operation	Closing coil	Coil burden (VA)	50		130		100		130	225			340		380		650		680
			Operating time (reference value) (ms)	10 ~ 15		15 ~ 25		15 ~ 25		15 ~ 25	30 ~ 40			30 ~ 50		30 ~ 50		40 ~ 60		80 ~ 100
		Tripping coil	Coil burden (VA)	65		135		135		135	300			600		630		350		480
			Operating time (reference value) (ms)	10 ~ 15		20 ~ 30		20 ~ 30		20 ~ 30	20 ~ 30			30 ~ 40		30 ~ 40		40 ~ 50		50 ~ 65
Auxiliary contact	Type of contacts		Twin contact								Twin contact									
	Numbers	Standard		1NC	1NO2NC					1NO2NC										3NO3NC
	Maximum		1NC	3NO4NC					3NO4NC										3NO3NC	
Mechanical interlock unit (reversible)			Provided as standard								Provided as standard									
DIN rail mounting (non-reversible)			Provided as standard																	
Life (million times)	Mechanical	1						0.5					0.25				0.25			
	Electrical (AC3)	0.5						0.5					0.1				0.05 (AC2)			
Available voltage range of operational coil (V)			24 ~ 220								24 ~ 220			100 ~ 220						

Notes:

1. Rating of Auxiliary Contact

Rated operational current					Rated thermal current	Minimum rating
AC(AC15)			DC L/R 40ms			
200 ~ 220V	380 ~ 440V	500 ~ 550V	48V	110V		
2A	1A	0.75A	0.7A	0.3A	10A	24V 10mA

2. Numbers of the auxiliary contacts are not included a NO contact for cutting off power source of tripping.

Notes:

1. Since operating time depends on coil voltage, frequency, phase etc., the contactors must not be applied for timing use.

4.6 Contactor Relays

Item		Numbers of contact		3 contacts				4 contacts				5 contacts				6 contacts				8 contacts							
Type		Standard type	Twin contacts type	Standard type	Twin contacts type	DC operation type	Latched type	Standard type	Twin contacts type	DC operation type	Latched type	Standard type	Twin contacts type	DC operation type	Latched type	Standard type	Twin contacts type	DC operation type	Standard type	Twin contacts type	DC operation type						
		X3	X3-W	X4	X4-W	X4-G	X4-L X4-LG	X5	X5-W	X5-G	X5-L X5-LG	X6	X6-W	X8	X8-W	X8-G											
Contact arrangement		3NO,2NO1NO 1NO2NC		4NO,3NO1NC 2NO2NC				3NO,2NO1NC 1NO2NC				5NO,4NO1NC 3NO2NC,2NO3NC				4NO,3NO1NC 2NO2NC,1NO3NC				6NO,5NO1NC 4NO2NC,3NO3NC				8NO,6NO2NC 5NO3NC,4NO4NC			
Rated insulation voltage		AC660V																									
Contact Rating	Rated thermal current (A)		15(3)A	10(2)A	15(3)A	10(2)A	15(3)A	15(3)A	15(3)A	10(2)A	15(3)A	15(3)A	15(3)A	10(2)A	15(3)A	15(3)A	10(2)A	15(3)A	15(3)A	10(2)A	15(3)A						
	Rated operational current (A)	AC (AC15)	200 ~ 220V	3	2	3	2	3	3	3	2	3	3	3	2	3	3	3	3	2	3						
			380 ~ 440V	2	1	2	1	3	3	3	3	1	3	3	2	1	3	3	2	1	3						
			500 ~ 550V	2	0.75	2	0.75	2	2	2	2	0.75	2	2	2	0.75	2	2	2	0.75	2						
	DC L/R 40ms	DC	48V	1	0.7	1	0.7	1	1	1	0.7	1	1	1	0.7	1	1	1	1	0.7	1						
			110V	0.4	0.3	0.4	0.3	0.4	0.4	0.4	0.3	0.4	0.4	0.4	0.3	0.4	0.4	0.4	0.3	0.4							
220V			0.2	0.1	0.2	0.1	0.2	0.2	0.2	0.1	0.2	0.2	0.2	0.1	0.2	0.2	0.2	0.1	0.2								
Minimum rating		48V, 10mA	24V, 10mA	48V, 10mA	24V, 10mA	48V, 10mA		48V, 10mA	24V, 10mA	48V, 10mA		48V, 10mA	24V, 10mA	48V, 10mA		48V, 10mA	24V, 10mA	48V, 10mA	24V, 10mA	48V, 10mA							
Coil burden (max.)		Pick-up	45/40VA		45/40VA		11W	45/40VA		11W	45/40VA		11W	45/40VA		11W	45/40VA		11W								
		Hold-in	9/7VA		9/7VA		11W	9/7VA		11W	9/7VA		11W	9/7VA		11W	9/7VA		11W								
Coil consumption 50/60Hz (W)(mean)		2.4/2		2.4/2		11		2.4/2		11		2.4/2		11		2.4/2		11									
Pick-up voltage (% of rated voltage)(mean)		55/60		60/65		50		65/70		55		60/65		65/70		55		60/65		65/70							
Drop-out voltage (% of rated voltage)(mean)		35/40		40/45		19		45/50		21		40/45		45/50		21		35/40		40/45							
Operating time (ms) (reference value)		Pick-up		5 ~ 20		5 ~ 20		15 ~ 25		5 ~ 20		25 ~ 30		5 ~ 20		5 ~ 20		15 ~ 25									
		Drop-out		6 ~ 36		6 ~ 36		15 ~ 20		6 ~ 36		10 ~ 15		6 ~ 26		6 ~ 26		10 ~ 15									
Characteristics of operation coil	Latched type	AC operation	Coil burden (VA)				45				45				45												
			Operating time (reference value) (ms)				10 ~ 15				10 ~ 15				10 ~ 15												
	DC operation	Tripping closing coil	Coil burden (VA)				55				55				55												
			Operating time (reference value) (ms)				9 ~ 13				9 ~ 13				9 ~ 13												
		Tripping closing coil	Coil burden (VA)				50				50				50												
			Operating time (reference value) (ms)				10 ~ 15				10 ~ 15				10 ~ 15												
DIN rail mounting		Provided as standard				Provided as standard				Provided as standard																	
Life (million times)		Mechanical		10		10		1		10		1		10		10											
		Electrical		1		1		0.5		1		0.5		1		1											
Available voltage range of operational coil (V)		24 ~ 550				24 ~ 220				24 ~ 550				24 ~ 220													

Notes:

- Numbers of the auxiliary contacts for latched type are not included a NO contact for cutting off the power source of tripping coil (marked).
- (1) DC operation and Twin contact type (X□-GW)
Contact Rating: see X□-W
Characteristics of operation coil: see X□-G
- (2) Latched and Twin contact type (X□-LW)
Contact Rating: see X□-W
Characteristics of operation coil: X□-L

Notes:

- Since operating time depends on coil voltage, frequency, phase etc., the contactors are not applied for timing use.

5. STANDARD TYPE ELECTROMAGNETIC STARTERS AND CONTACTORS

5.1 Coil Specifications

STANDARD SPECIFICATION TABLE OF COIL

	Voltage/Frequency	Coil tap	Terminal code
8C ~ 125C	100V 50Hz/100 ~ 110V 60Hz	Common tap for 50Hz, 60Hz	
	200V 50Hz/200 ~ 220V 60Hz		
	400V 50Hz/400 ~ 440V 60Hz		
150C ~ 800C	100 ~ 110V 50/60Hz		
	200 ~ 220V 50/60Hz		
	400 ~ 440V 50/60Hz		

RATED OPERATIONAL VOLTAGE AND COLOR CLASSIFICATION OF COIL

Color of outer wrapping and lead wire (COMMON line)	Rated operational voltage and frequency	
	8C ~ 125C	
Yellow	100V	50Hz
	100 ~ 110V	60Hz
White	200V	50Hz
	200 ~ 220V	60Hz
Red	400V	50Hz
	400 ~ 440V	60Hz
Blue	Exclusive coil for all voltages* and frequencies used other than the above.	

NOTES:

- For example, 200 ~ 220V, 60Hz includes all those of voltages between 200V and 220V. In case no special request is received, shipment will be made under the standard coil voltage indication even in case of 210V, 60Hz.

2. *

Frame	Manufacturable voltage range
8C ~ 125C	24V ~ 550V
150C ~ 800C	100V ~ 440V

5.2 Performance

All models of Hitachi magnetic starters and contactors conform to the international standard (IEC 60947-4-1).

Frame	Making capacity*	Breaking capacity*	Applicable operating frequency	Life (million times)	
				Electrical	Mechanical
8C ~ 12	Not less than 10 times rated current	Not less than 8 times rated current	1200 operations per hour	2	10
20				2	5
10B, 25 ~ 200C				1	5
250C ~ 600C				0.5	5

*Conform to category AC3 of IEC 60947-4-1

5.3 Application for the International Standards

Rated insulation voltage (V)	IEC 60947-4-1	NEMA	BS	VDE
150	All Frames	8C, 10C, 11, 12 10B, 25 Frame	All Frames	All Frames
250				
300				
380				
500				
600				
660	-	-	-	-

5.4 Normal Service Condition

- Ambient temperature: $\frac{\text{without enclosure}}{\text{with enclosure}} \left| \begin{array}{l} - 5 \sim 50 \\ - 5 \sim 40 \end{array} \right.$
- Relative humidity: 45% ~ 85%
- Altitude: 2,000m or lower
- Atmosphere: must be free from corrosive gas, combustible gas, dust, vapor, salt etc.
- Environment: must be free from excessive vibration or shock.

5.5 Selection

Application of Cases Including Inching and Plugging (Category AC4)

In equipment and machinery which include inching and plugging (negative-phase braking), make and break of large starting rush current of motor will occur frequently. Category AC4 is applied for such usage. The rating of electromagnetic contactor is AC3. However, Category AC4 can be applied by lowering the rating.

Application examples for motors when assuming that starting rush current (inching current) of the motor is about 6 times that of the rated operational current are shown in Tables 1 and 2.

TABLE 1 INCHING (AC4)

Motor capacity (kW)	Inching ratio 50%				Inching ratio 75 ~ 100%			
	Electrical life 0.1 million times		Electrical life 0.5 million times		Electrical life 0.1 million times		Electrical life 0.5 million times	
	200 ~ 240V	380 ~ 440V	200 ~ 240V	380 ~ 440V	200 ~ 240V	380 ~ 440V	200 ~ 240V	380 ~ 440V
0.1	H10C	H10C	H10C	H10C	H10C	H10C	H10C	H10C
0.2	"	"	"	"	"	"	"	"
0.4	"	"	"	"	"	"	"	"
0.75	"	"	H20	"	"	"	H20	H20
1.5	"	"	H25	H20	H20	"	H35	"
2.2	H20	"	H35	H25	H25	H20	H50	H35
3.7	H25	H20	H65C	H35	H35	H25	H80C	H50
5.5	H35	H25	H80C	H50	H65C	H35	H150C	H65C
7.5	H50	H35	H150C	H65C	H80C	H50	"	H80C
9	H65C	H50	"	H80C	"	H65C	H200C	H150C
11	H80C	"	"	"	H150C	"	"	"
13	"	H65C	H200C	H150C	"	H80C	H250C	"
15	H150C	"	"	"	"	H150C	H300C	"
18.5	"	H80C	H250C	"	H200C	"	H400C	H200C
22	"	H150C	H300C	H200C	H250C	"	H600C	H300C
30	H200C	"	H600C	H250C	H300C	H200C	"	H400C
37	H250C	H200C	"	H300C	H600C	H300C	-	H600C
45	H300C	H250C	-	H600C	"	H600C	-	-
55	H600C	H300C	-	-	-	-	-	-
75	-	H600C	-	-	-	-	-	-

TABLE 2 PLUGGING (AC4)

Motor capacity (kW)	Plugging			
	Electrical life 0.1 million times		Electrical life 0.5 million times	
	200 ~ 240V	380 ~ 440V	200 ~ 240V	380 ~ 440V
0.2	H10B-R	H10B-R	H10B-R	H10B-R
0.4	"	"	"	"
0.75	"	"	H20-R	H20-R
1.5	H20-R	H20-R	H35-R	"
2.2	H25-R	"	H50-R	H35-R
3.7	H35-R	H35-R	H80C-R	H50-R
5.5	H65C-R	H50-R	H150C-R	H65C-R
7.5	H80C-R	H65C-R	"	H80C-R
11	H150C-R	H80C-R	H200C-R	H150C-R
15	"	H150C-R	H300C-R	"
18.5	H200C-R	"	H400C-R	H200C-R
22	H250C-R	"	H600C-R	H300C-R
30	H300C-R	H200C-R	"	H400C-R
37	H600C-R	H300C-R	-	H600C-R
45	"	H600C-R	-	-

NOTES:

- Inching ratio (%) means
$$\frac{\text{Inching operation}}{\text{Inching operation} + \text{Normal operation (Category AC3)}} \times 100(\%)$$
- Please enquire when using high inching frequency machine tools, hoists, cranes, etc., with an inching ratio of about 75 ~ 100%.

Application to AC Resistance Load

Category AC1 is applied when using a resistance load which does not necessitate consideration of rush current at starting such as the incandescent light, electric heater, etc.

Application of electromagnetic contactor to Category AC1 is shown in Table 3.

TABLE 3

Type	Category AC1 rating			
	Rated operational current (A)		Three-phase heater capacity (kW)	
	200 ~ 240V	380 ~ 440V	200 ~ 240V	380 ~ 440V
H8C, H10C, H11, H12	20 (15)	20 (15)	6 (5)	12 (10)
H20	32 (26)	32 (26)	10 (9)	20 (18)
H25	35 (35)	35 (35)	12 (12)	24 (24)
H35	50 (44)	50 (44)	17 (15)	34 (30)
H50	70 (60)	70 (60)	24 (20)	48 (40)
H65C	80 (65)	80 (65)	27 (22)	54 (45)
H80C	120 (80)	120 (80)	40 (27)	80 (55)
H100C	135 (100)	135 (100)	46 (34)	92 (69)
H125C	150 (125)	150 (125)	50 (43)	120 (86)
H150C	200 (150)	200 (150)	65 (50)	130 (100)
H200C	260 (180)	260 (180)	90 (60)	180 (120)
H250C	300 (240)	300 (240)	100 (80)	200 (160)
H300C	350 (300)	350 (300)	120 (100)	240 (200)
H400C	420 (400)	420 (400)	145 (135)	290 (270)
H600C	600 (600)	600 (600)	200 (200)	410 (410)
H800C	800	800	270	540

Notes:

- 1) The electrical life is 0.5 million times.
- 2) Category AC1 is not applied to loads such as of mercury lamps where a large rush current flows at starting, and uses where resistance load is controlled at the primary side of the transformer.
- 3) Values of () are applied to Enclosure type.

Application to DC Load

The breaking category of DC load becomes far more severe in comparison with AC load. However, electromagnetic contactor can

be applied as shown in Table 4.

TABLE 4

Type of load	Time constant L/R (ms)	Voltage DC (V)	No. of series contacts	Frame and rated operational current (A)											
				8C, 10C, 11	20	25	35	50	65C	80C	100C, 125C	150C	200C, 250C	300C, 400C	600C
Resistance load	Less than 1	24	1	15	25	30	50	60	70	90	120	170	200	300	600
		48	1	15	25	30	50	60	70	90	120	170	200	300	600
			2	15	25	30	50	60	70	90	120	170	200	300	600
		110	2	15	25	30	50	60	70	90	120	170	200	300	600
3	15		25	30	50	60	70	90	120	170	200	300	600		
DC motor	Less than 15	24	1	6	10	10	20	20	25	35	40	60	100	150	300
		48	2	6	15	15	20	20	25	50	60	80	120	150	300
			3	10	20	20	30	30	35	80	90	120	180	200	300
		110	2	4	8	8	10	10	15	30	40	60	100	150	300
3	8		15	15	20	20	30	60	80	100	150	200	300		
Coil load	Less than 40	24	1	3	5	5	7	7	10	20	20	-	-	-	-
		48	1	3	5	5	7	7	10	20	20	-	-	-	-
			2	5	15	15	20	20	25	50	60	-	-	-	-
		110	2	3	5	5	7	7	10	20	20	-	-	-	-
3	7		15	15	20	20	25	50	60	-	-	-	-		
Coil load	Less than 100	24	1	2	3	3	5	5	7	10	10	-	-	-	-
		48	1	2	3	3	5	5	7	10	10	-	-	-	-
			2	5	7	10	15	15	15	30	35	-	-	-	-
		110	2	2	3	3	5	5	7	10	10	-	-	-	-
3	5		7	10	15	15	15	30	35	-	-	-	-		
Coil load	Less than 100	24	1	2	3	3	5	5	7	10	10	-	-	-	-
		2	5	7	10	15	15	15	30	35	-	-	-	-	
Coil load	Less than 100	24	1	2	3	3	5	5	7	10	10	-	-	-	-
		2	5	7	10	15	15	15	30	35	-	-	-	-	
Coil load	Less than 100	24	1	2	3	3	5	5	7	10	10	-	-	-	-
		2	5	7	10	15	15	15	30	35	-	-	-	-	

Notes:

- 1) Contact series connection method

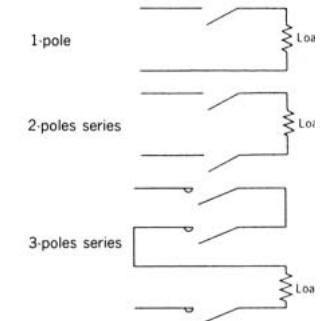

- 2) Electrical life is 0.25 million times.

5.6 Cautions

Allowable installation angle

Normal installation is made on the perpendicular plane as shown in Fig. b. As shown in Fig. a, the installation position with an inclination of up to 15° to the left and right and back and forth is permissible.

Limited to models of frames 8C ~ 125C, side installation, in the condition where it is turned 90° in counterclockwise direction from the normal installation position, can also be made as shown in Fig. c, but in unavoidable cases. However, its life will be shortened by about 20%.



Fig. a Allowable installation angle



Fig. b Normal installation



Fig. c Side installation

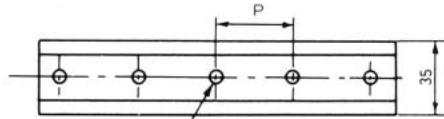

Fig. d

Screw for rail mounting

Special screw

Sometimes a special screw (unitized screw and spring washer) is used in the coupling section of the electromagnetic contactor and thermal overload relay in an electromagnetic starter.

The special screw has an incomplete thread section so when using the thermal overload relay disconnected from the contactor, tighten the screw by inserting a plane washer, etc., so that the incomplete thread section is not screwed into terminal plate.

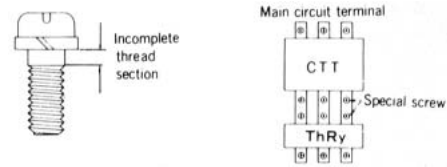

Cautions of Rail Mounting Type

- (1) Interval of screws for rail mounting
Interval of screws for rail mounting - as shown in Fig. d - shall be as follows.
 - Contactor relays and 8C ~ 12 frame: P 300mm
 - 20 ~ 50 frame: P 200mm
- (2) Mounting space of switches
Mounting space of switches - as shown in Fig. e - shall be as follows.
 - Contactor relay: l 0mm
 - Contactor starter: l 5mm
- (3) Side installation is not allowed as shown in Fig. f.

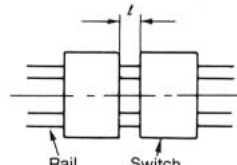

Fig. e

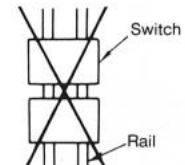

Fig. f

Applicable wires and suitable tightening torques

Frame	Specifications		Main circuit					Operating circuit					Contactor				
	Motor capacity 200V Class (kW)	Rated operational current 200V Class (A)	Terminal screw (mm)		Connectable wire (mm ²)	Maximum width of usable solderless terminal (mm)	Suitable tighten- ing torque (N · m)		Terminal screw (mm)		Connectable wire (mm ²)	Maximum width of usable solderless terminal (mm)	Suitable tighten- ing torque (N · m)		Mounting screw		Suitable tightening torque (N · m)
			Electro- magnetic contactor	Thermal overload relay			Electro- magnetic contactor	Thermal overload relay	Electro- magnetic contactor	Thermal overload relay			Electro- magnetic contactor	Thermal overload relay	Screw diameter (mm)	Number of screws	
8C	2.5	11	M3.5		($\frac{1.6}{2}$)	7.8	1	M3.5	($\frac{1.6}{2}$)	7.8	1	M4	2	1.5			
10C 10B	3	12	M3.5		($\frac{1.6}{2}$)	7.8	1	M3.5	($\frac{1.6}{2}$)	7.8	1	M4	2	1.5			
11 12	3	12	M3.5		($\frac{1.6}{2}$)	7.8	1	M3.5	($\frac{1.6}{2}$)	7.8	1	M4	2	1.5			
20	5.5	22	M4		($\frac{2}{3.5}$)	9	1.5	M3.5	($\frac{1.6}{2}$)	7.8	1	M4	2	1.5			
25	7.5	27	M5		($\frac{2.6}{8}$)	10	3.5	M3.5	($\frac{1.6}{2}$)	7.8	1	M4	2	1.5			
35	11	39	M5		($\frac{3.2}{14}$)	12.5	3.5	M3.5	($\frac{1.6}{2}$)	7.8	1	M4	2	1.5			
50	15	52	M5			14	3.5	M3.5	($\frac{1.6}{2}$)	7.8	1	M4	2	1.5			
65C	18.5	65	M6			22	5	M3.5	($\frac{1.6}{2}$)	7.8	1	M4	2	1.5			
80C	22	80	M6			60	22	5	M3.5	($\frac{1.6}{2}$)	7.8	1	M5	2	3.5		
100C	30	105	M8 bolt			60	22	14	M3.5	($\frac{1.6}{2}$)	7.8	1	M5	2	3.5		
125C	37	126	M8 bolt			60	22	14	M3.5	($\frac{1.6}{2}$)	7.8	1	M6	2	5		
150C	45	150	M8 bolt			80	27	14	M3.5	($\frac{1.6}{2}$)	7.8	1	M6	2	5		
200C	55	182	M10 bolt	-		150	37	25	M3.5	($\frac{1.6}{2}$)	7.8	1	M8 bolt	4	14		
250C	75	240	M10 bolt	-		150	37	25	M3.5	($\frac{1.6}{2}$)	7.8	1	M8 bolt	4	14		
300C	90	300	M12 bolt	-		200	44	45	M3.5	($\frac{1.6}{2}$)	7.8	1	M8 bolt	4	14		
400C	115	400	M12 bolt	-		200	44	45	M3.5	($\frac{1.6}{2}$)	7.8	1	M8 bolt	4	14		
600C	160	600	M12 bolt	-		325	55	45	M4	M3.5	($\frac{1.6}{2}$)	7.8	1.5	1	M10 bolt	4	25







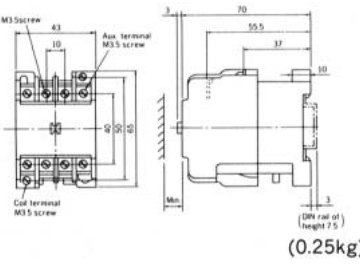
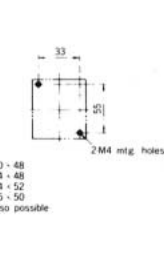
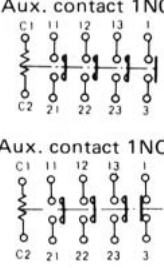
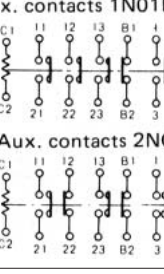

Note: Except for certain special cases, the following are used for wiring of operating circuit electric wires, circuits of auxiliary contacts, etc.

Single wire: 1.6 600V polyvinyl chloride wire

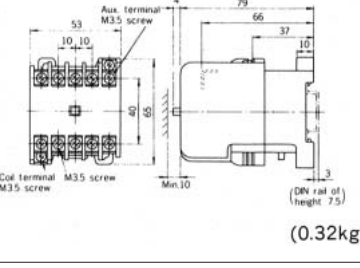
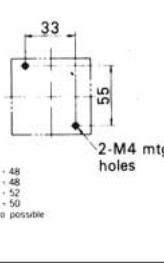
Standard wire: 1.25 or 2 mm² 600V polyvinyl chloride wire

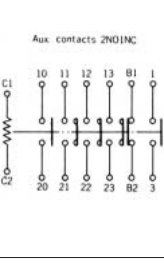
5.7 Appearance and Dimensions

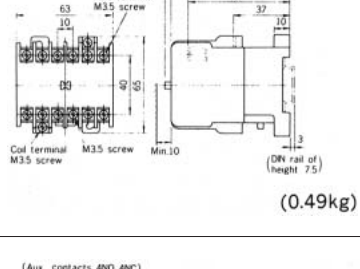
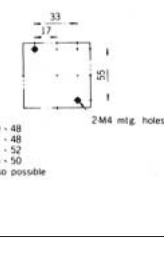
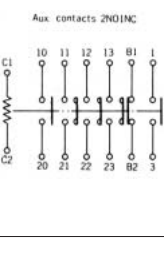
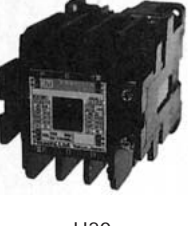
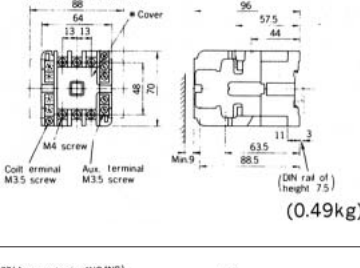
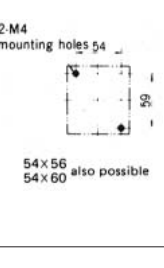
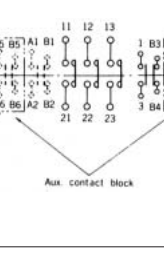
Non-Reversible Electromagnetic Contactors without Enclosure

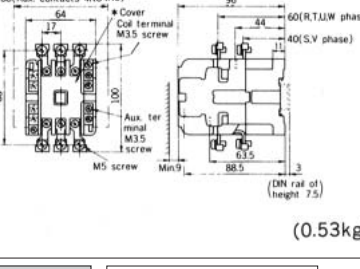
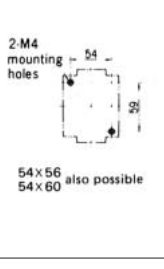
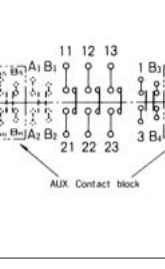



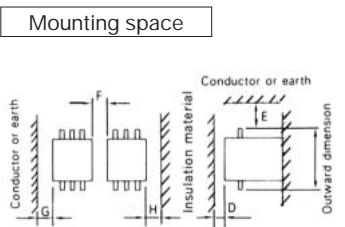

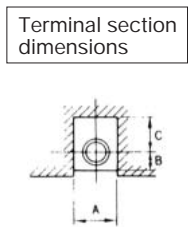
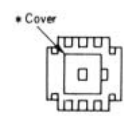

Appearance	Dimensions (mm) (Product weight)	Drilling plan	Contact arrangement	Terminal section dimensions (mm)			
 <p>H8C, H10C</p>	 <p>(0.25kg)</p>	 <p>2-M4 mtg. holes</p>	<p>Aux. contact 1NO</p>  <p>Aux. contact 1NC</p> 	Main circuit	Terminal screw	M3.5	
					Operating circuit	Terminal dimensions	A
						B	5
					C	4.8	
 <p>H11</p>	 <p>(0.32kg)</p>	 <p>2-M4 mtg. holes</p>	<p>Aux. contacts 1NO1NC</p>  <p>Aux. contacts 2NC</p> 	Main circuit	Terminal screw	M3.5	
					Operating circuit	Terminal dimensions	A
						B	5.5
					C	4.8	
 <p>H12</p>	 <p>(0.49kg)</p>	 <p>2-M4 mtg. holes</p>	<p>Aux. contacts 2NO1NC</p> 	Main circuit	Terminal screw	M3.5	
					Operating circuit	Terminal dimensions	A
						B	5.5
					C	4.8	
 <p>H20</p>	 <p>(0.49kg)</p>	 <p>2-M4 mounting holes 54 54x56 54x60 also possible</p>	 <p>Aux. contact block</p>	Main circuit	Terminal screw	M4	
					Operating circuit	Terminal dimensions	A
						B	4.5
					C	5.5	
 <p>H25</p>	 <p>(0.53kg)</p>	 <p>2-M4 mounting holes 54 54x56 54x60 also possible</p>	 <p>AUX Contact block</p>	Main circuit	Terminal screw	M5	
					Operating circuit	Terminal dimensions	A
						B	6
					C	8.5	
					Terminal screw	M3.5	
					Terminal dimensions	A	7.8
						B	5.5
						C	4.8

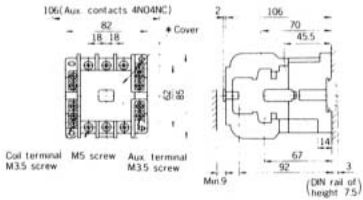
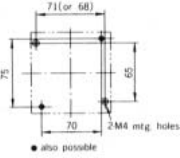
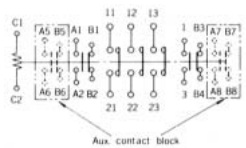
Type	Minimum mounting space (mm)				
	D	E	F	G	H
H8C, H10C	10	15	5	10	5
H11	10	15	5	10	5
H12	10	15	5	10	5
H20	9	15	5	10	5
H25	9	15	5	10	5

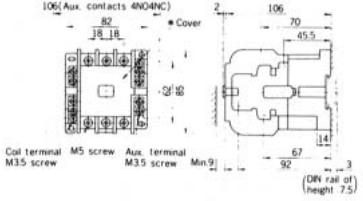
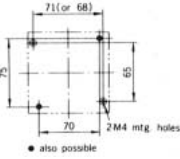
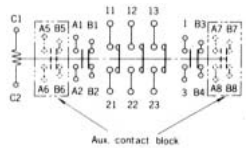

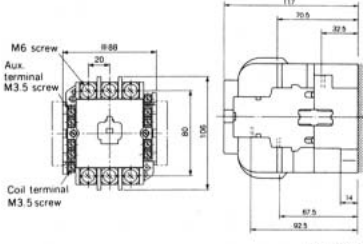
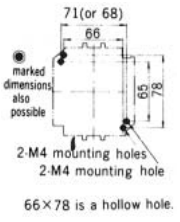
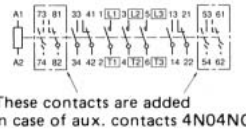

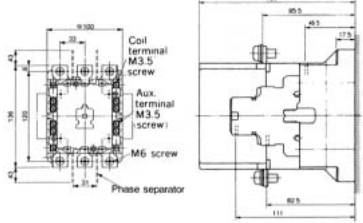
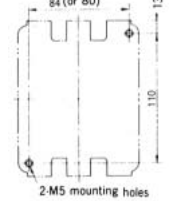
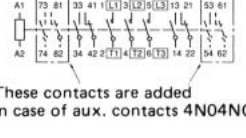

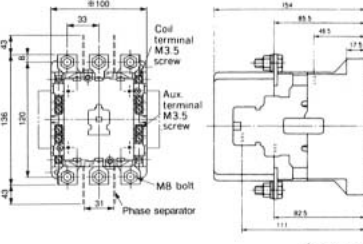
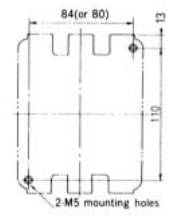
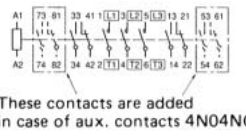
Note: Do not operate with the cover removed (Check by removing the contact and always be sure to securely push in the cover after checking).

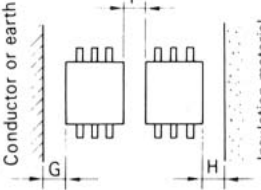
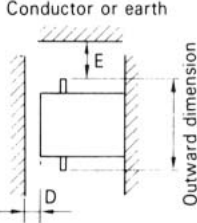
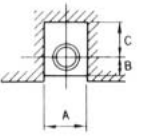

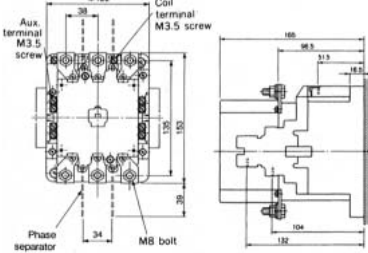

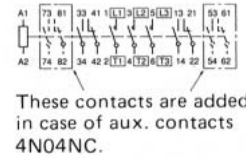

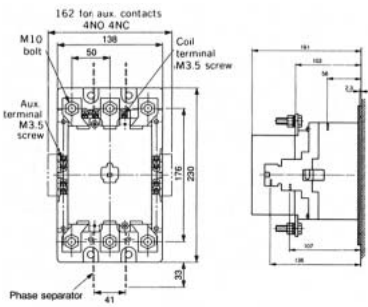
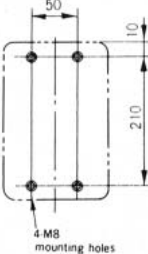
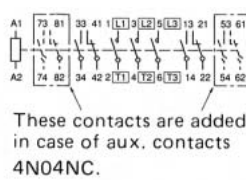
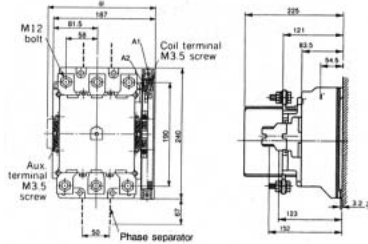
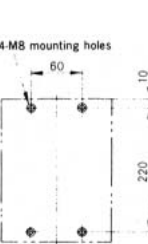
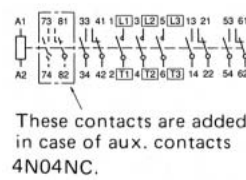
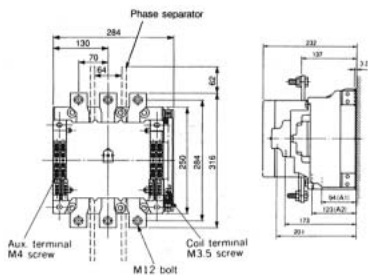
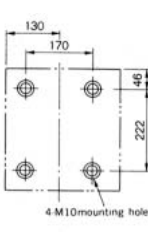
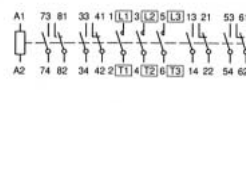

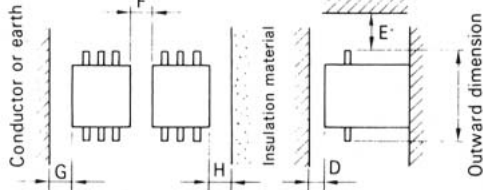
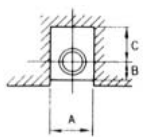

Appearance	Dimensions (mm) (Product weight)	Drilling plan	Contact arrangement	Terminal section dimensions (mm)	
 <p>H35</p>	 <p>(0.77kg)</p>			Main circuit	Terminal screw: M5
				Operating circuit	Terminal screw: M3.5
 <p>H50</p>	 <p>(0.77kg)</p>			Main circuit	Terminal screw: M5
				Operating circuit	Terminal screw: M3.5
 <p>H65C</p>	 <p>(1.2kg)</p>		 <p>These contacts are added in case of aux. contacts 4N04NC.</p>	Main circuit	Terminal screw: M6
				Operating circuit	Terminal screw: M3.5
 <p>H80C</p>	 <p>(2.0kg)</p>		 <p>These contacts are added in case of aux. contacts 4N04NC.</p>	Main circuit	Terminal screw: M6
				Operating circuit	Terminal screw: M3.5
 <p>H100C, H125C</p>	 <p>(2.0 kg)</p>		 <p>These contacts are added in case of aux. contacts 4N04NC.</p>	Main circuit	Terminal screw: M8 bolt
				Operating circuit	Terminal screw: M3.5

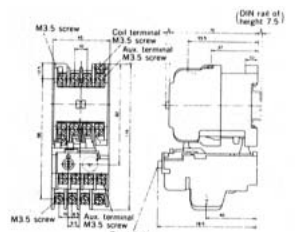
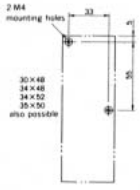
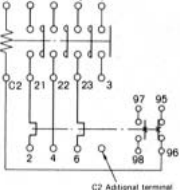
Type	Dimensions					Minimum mounting space (mm)	Mounting space	Conductor or earth	Terminal section dimensions
	D	E	F	G	H				
H35	9	15	5	10	5				
H50	9	15	5	10	5				
H65C	1	15	5	10	5				
H80C	1	15	10	10	10				
H100C, H125C	1	15	10	10	10				

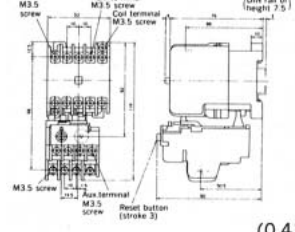
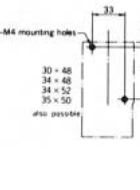
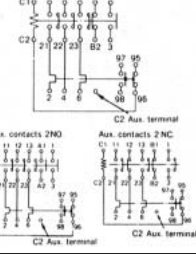
Appearance	Dimensions (mm) (Product weight)	Drilling plan	Contact arrangement	Terminal section dimensions (mm)										
 H150C	 (3.3kg)	 2 M6 M mounting holes	 These contacts are added in case of aux. contacts 4N04NC.	<table border="1"> <tr> <td rowspan="3">Main circuit</td> <td>Terminal screw</td> <td>M8 bolt</td> </tr> <tr> <td rowspan="3">Terminal dimensions</td> <td>A</td> <td>27</td> </tr> <tr> <td>B</td> <td>10</td> </tr> <tr> <td>C</td> <td>9.5</td> </tr> </table>	Main circuit	Terminal screw	M8 bolt	Terminal dimensions	A	27	B	10	C	9.5
				Main circuit		Terminal screw	M8 bolt							
Terminal dimensions	A	27												
	B	10												
	C	9.5												
<table border="1"> <tr> <td rowspan="3">Operating circuit</td> <td>Terminal screw</td> <td>M3.5</td> </tr> <tr> <td rowspan="3">Terminal dimensions</td> <td>A</td> <td>7.8</td> </tr> <tr> <td>B</td> <td>6</td> </tr> <tr> <td>C</td> <td>4.5</td> </tr> </table>	Operating circuit	Terminal screw	M3.5	Terminal dimensions	A	7.8	B	6	C	4.5				
Operating circuit		Terminal screw	M3.5											
		Terminal dimensions	A		7.8									
	B		6											
C	4.5													
 H200C, H250C	 (5.5kg)	 4 M8 mounting holes	 These contacts are added in case of aux. contacts 4N04NC.	<table border="1"> <tr> <td rowspan="3">Main circuit</td> <td>Terminal screw</td> <td>M10 bolt</td> </tr> <tr> <td rowspan="3">Terminal dimensions</td> <td>A</td> <td>37</td> </tr> <tr> <td>B</td> <td>12.5</td> </tr> <tr> <td>C</td> <td>16</td> </tr> </table>	Main circuit	Terminal screw	M10 bolt	Terminal dimensions	A	37	B	12.5	C	16
				Main circuit		Terminal screw	M10 bolt							
Terminal dimensions	A	37												
	B	12.5												
	C	16												
<table border="1"> <tr> <td rowspan="3">Operating circuit</td> <td>Terminal screw</td> <td>M3.5</td> </tr> <tr> <td rowspan="3">Terminal dimensions</td> <td>A</td> <td>7.8</td> </tr> <tr> <td>B</td> <td>6</td> </tr> <tr> <td>C</td> <td>4.5</td> </tr> </table>	Operating circuit	Terminal screw	M3.5	Terminal dimensions	A	7.8	B	6	C	4.5				
Operating circuit		Terminal screw	M3.5											
		Terminal dimensions	A		7.8									
	B		6											
C	4.5													
H300C, H400C	 (9.7kg)	 4 M8 mounting holes	 These contacts are added in case of aux. contacts 4N04NC.	<table border="1"> <tr> <td rowspan="3">Main circuit</td> <td>Terminal screw</td> <td>M12 bolt</td> </tr> <tr> <td rowspan="3">Terminal dimensions</td> <td>A</td> <td>44</td> </tr> <tr> <td>B</td> <td>15</td> </tr> <tr> <td>C</td> <td>20</td> </tr> </table>	Main circuit	Terminal screw	M12 bolt	Terminal dimensions	A	44	B	15	C	20
				Main circuit		Terminal screw	M12 bolt							
Terminal dimensions	A	44												
	B	15												
	C	20												
<table border="1"> <tr> <td rowspan="3">Operating circuit</td> <td>Terminal screw</td> <td>M3.5</td> </tr> <tr> <td rowspan="3">Terminal dimensions</td> <td>A</td> <td>7.8</td> </tr> <tr> <td>B</td> <td>6</td> </tr> <tr> <td>C</td> <td>4.5</td> </tr> </table>	Operating circuit	Terminal screw	M3.5	Terminal dimensions	A	7.8	B	6	C	4.5				
Operating circuit		Terminal screw	M3.5											
		Terminal dimensions	A		7.8									
	B		6											
C	4.5													
H600C	 (22kg)	 4 M10 mounting holes	 These contacts are added in case of aux. contacts 4N04NC.	<table border="1"> <tr> <td rowspan="3">Main circuit</td> <td>Terminal screw</td> <td>M12 bolt</td> </tr> <tr> <td rowspan="3">Terminal dimensions</td> <td>A</td> <td>55</td> </tr> <tr> <td>B</td> <td>16</td> </tr> <tr> <td>C</td> <td>28</td> </tr> </table>	Main circuit	Terminal screw	M12 bolt	Terminal dimensions	A	55	B	16	C	28
				Main circuit		Terminal screw	M12 bolt							
Terminal dimensions	A	55												
	B	16												
	C	28												
<table border="1"> <tr> <td rowspan="3">Operating circuit</td> <td>Terminal screw</td> <td>M4</td> </tr> <tr> <td rowspan="3">Terminal dimensions</td> <td>A</td> <td>9</td> </tr> <tr> <td>B</td> <td>7.2</td> </tr> <tr> <td>C</td> <td>5</td> </tr> </table>	Operating circuit	Terminal screw	M4	Terminal dimensions	A	9	B	7.2	C	5				
Operating circuit		Terminal screw	M4											
		Terminal dimensions	A		9									
	B		7.2											
C	5													

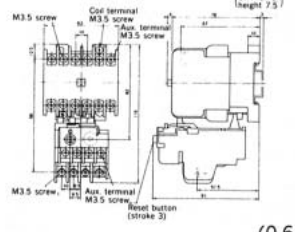
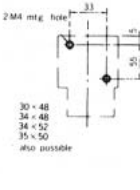
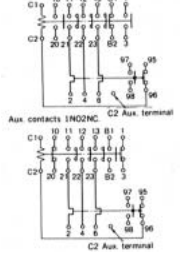
Dimensions Type	Minimum mounting space (mm)					Mounting space	Conductor or earth	Terminal section dimensions
	D	E	F	G	H			
H150C	1	15	10	10	10			
H200C, H250C	1	20	10	10	10			
H300C, H400C	1	30	10	10	10			
H600C	1	50	10	10	10			

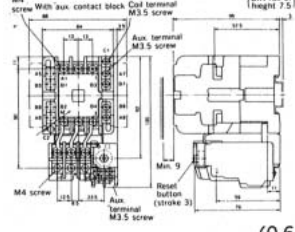
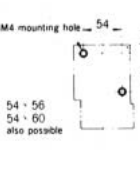
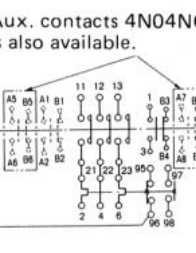
Non-Reversible Electromagnetic Starters without Enclosure

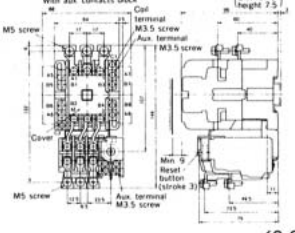
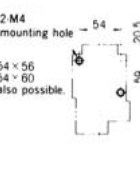
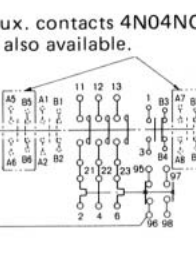
Appearance	Dimensions (mm) (Product weight)	Drilling plan	Contact arrangement	Terminal section dimensions (mm)			
				Terminal screw	Electro-magnetic contactor	Thermal overload relay	
 B) H8-T B) H10C-T	 (0.34kg)			Main circuit	Terminal screw	M3.5	M3.5
					Terminal dimensions	A	7.8
B	5	6					
Operating circuit	Terminal screw	M3.5	M3.5				
		A	7.8	7.6			
		B	5	4			
C	4.8	4.5					
 B) H11-T	 (0.41kg)			Main circuit	Terminal screw	M3.5	M3.5
					Terminal dimensions	A	7.8
B	5.5	6					
Operating circuit	Terminal screw	M3.5	M3.5				
		A	7.8	7.6			
		B	5.5	4			
C	4.8	4.5					
 B) H12-T	 (0.65kg)			Main circuit	Terminal screw	M3.5	M3.5
					Terminal dimensions	A	7.8
B	5.5	6					
Operating circuit	Terminal screw	M3.5	M3.5				
		A	7.8	7.6			
		B	5.5	4			
C	4.8	4.5					
 B) H20-T	 (0.65kg)			Main circuit	Terminal screw	M4	M4
					Terminal dimensions	A	9
B	4.5	9					
Operating circuit	Terminal screw	M3.5	M3.5				
		A	7.8	7.8			
		B	5.5	4			
C	4.8	4.5					
 B) H25-T	 (0.69kg)			Main circuit	Terminal screw	M5	M5
					Terminal dimensions	A	10
B	6	6					
Operating circuit	Terminal screw	M3.5	M3.5				
		A	7.8	7.6			
		B	5.5	4			
C	4.8	4.5					

Type	Minimum mounting space (mm)				
	D	E	F	G	H
B) H8C-T	10	15	5	10	5
B) H10C-T	10	15	5	10	5
B) H11-T	10	15	5	10	5
B) H12-T	10	15	5	10	5
B) H20-T	9	15	5	10	5
B) H25-T	9	15	5	10	5

Mounting space

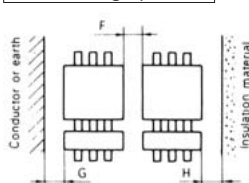



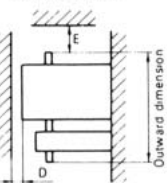



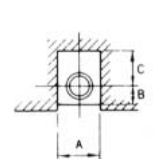

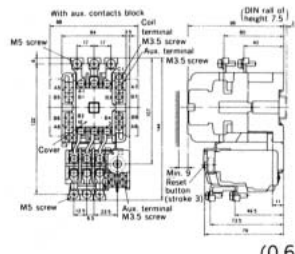
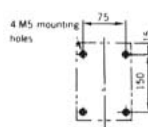
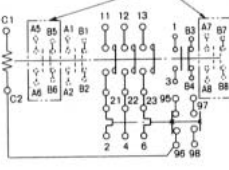

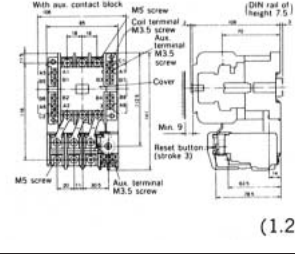
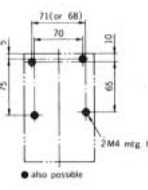
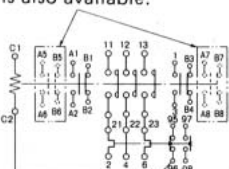
Conductor or earth

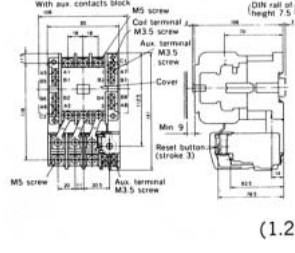
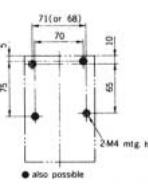
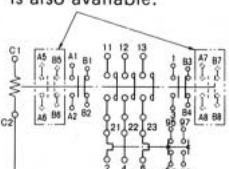

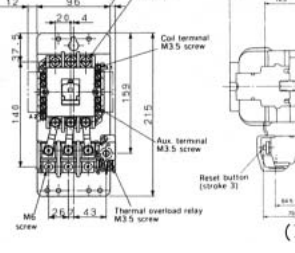
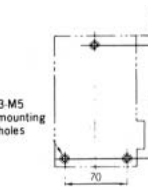
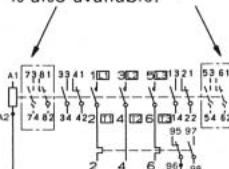

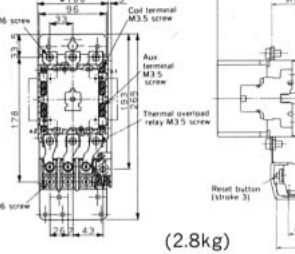
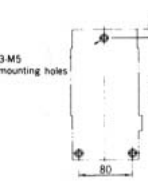

Terminal section dimensions

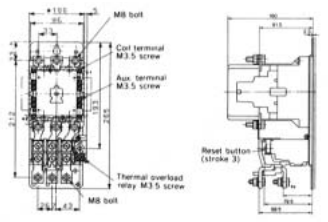
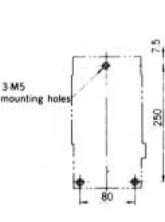
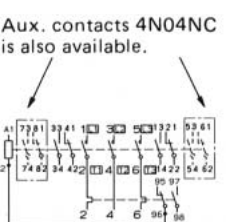

Appearance	Dimensions (mm) (Product weight)	Drilling plan	Contact arrangement	Terminal section dimensions (mm)			
				Electro-magnetic contactor	Thermal overload relay		
 B) H25-T (With TR40-1E)	 (0.69kg)		 Aux. contacts 4N04NC is also available.	Main circuit	Terminal screw	M5	M5
					Terminal dimensions	A	10
B	6	6.5					
Operating circuit	Terminal screw	M3.5	M3.5				
		Terminal dimensions	A	7.8	7.8		
			B	5.5	4		
C	4.8	4.5					
 B) H35-T	 (1.24kg)		 Aux. contacts 4N04NC is also available.	Main circuit	Terminal screw	M5	M5
					Terminal dimensions	A	12.5
B	6	6.5					
C	8	7					
Operating circuit	Terminal screw	M3.5	M3.5				
		Terminal dimensions	A	7.8	7.8		
			B	5.5	4		
C	4.8	4.5					
 B) H50-T	 (1.24kg)		 Aux. contacts 4N04NC is also available.	Main circuit	Terminal screw	M5	M5
					Terminal dimensions	A	12.5
B	6	6.5					
C	8	7					
Operating circuit	Terminal screw	M3.5	M3.5				
		Terminal dimensions	A	7.8	7.8		
			B	5.5	4		
C	4.8	4.5					
 H65C-T	 (1.9kg)		 Aux. contacts 4N04NC is also available.	Main circuit	Terminal screw	M6	M6
					Terminal dimensions	A	16.5
B	8	8.5					
C	8	8					
Operating circuit	Terminal screw	M3.5	M3.5				
		Terminal dimensions	A	7.8	7.8		
			B	5.5	4		
C	4.5	4.5					
 H80C-T	 (2.8kg)		 Aux. contacts 4N04NC is also available.	Main circuit	Terminal screw	M6	M6
					Terminal dimensions	A	22
B	8	8.5					
C	11	8					
Operating circuit	Terminal screw	M3.5	M3.5				
		Terminal dimensions	A	7.8	7.8		
			B	5	4		
C	4.5	4.5					

Type	Dimensions					Minimum mounting space (mm)		Mounting space		Conductor or earth		Terminal section dimensions	
	D	E	F	G	H	F	H	D	Outward dimension	A	B	C	
H25-T	9	15	5	10	5								
H35-T	9	15	5	10	5								
H50-T	9	15	5	10	5								
H65C-T	1	15	5	10	5								
H80C-T	1	15	10	10	10								

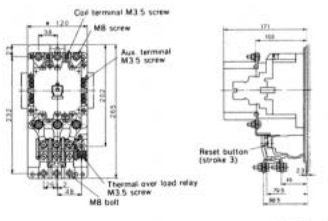
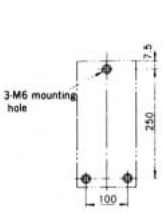
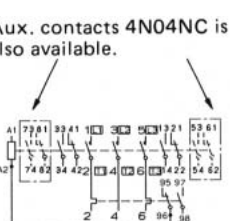
Non-Reversible Electromagnetic Starters without Enclosure

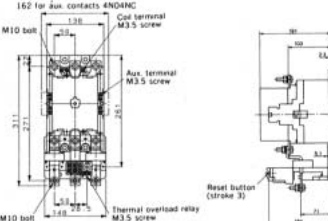
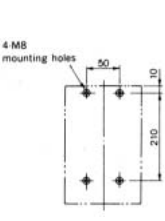
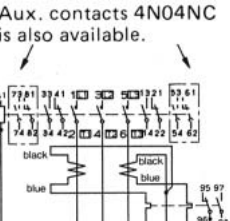
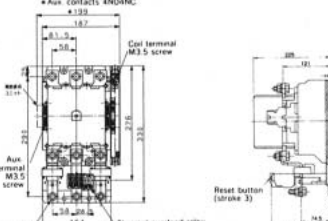
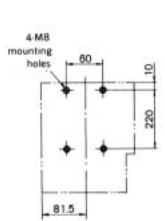
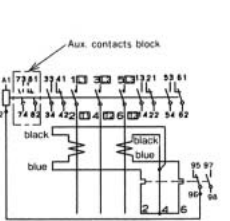
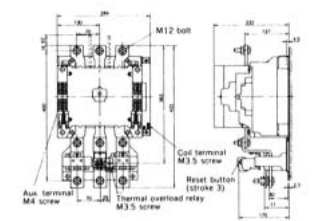
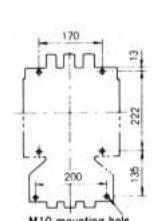
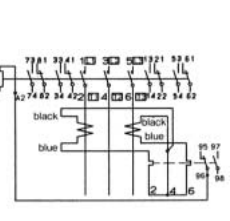
Appearance	Dimensions (mm) (Product weight)	Drilling plan	Contact arrangement	Terminal section dimensions (mm)				
				Electro-magnetic contactor	Thermal overload relay			
 <p>H100C-T H125C-T</p>	 <p>(3.0kg)</p>		 <p>Aux. contacts 4N04NC is also available.</p>	Main circuit	Terminal screw	M8 bolt	M8 bolt	
					Terminal dimensions	A	22	27
						B	8	10
				Operating circuit	Terminal screw	M3.5	M3.5	
Terminal dimensions	A	7.8	7.8					
	B	5	4					
C	4.5	4.5						
 <p>H150C-T</p>	 <p>(3.9kg)</p>		 <p>Aux. contacts 4N04NC is also available.</p>	Main circuit	Terminal screw	M8 bolt	M8 bolt	
					Terminal dimensions	A	27	27
						B	10	10
				Operating circuit	Terminal screw	M3.5	M3.5	
Terminal dimensions	A	7.8	7.8					
	B	6	4					
C	4.5	4.5						
 <p>H200C-T H250C-T</p>	 <p>(7.2kg)</p>		 <p>Aux. contacts 4N04NC is also available.</p>	Main circuit	Terminal screw	M12 bolt	-	
					Terminal dimensions	A	37	-
						B	12.5	-
				Operating circuit	Terminal screw	M3.5	M3.5	
Terminal dimensions	A	7.8	7.8					
	B	6	4					
C	4.5	4.5						
<p>H300C-T H400C-T</p>	 <p>(12kg)</p>		 <p>Aux. contacts block</p>	Main circuit	Terminal screw	M10 bolt	-	
					Terminal dimensions	A	44	-
						B	15	-
				Operating circuit	Terminal screw	M3.5	M3.5	
Terminal dimensions	A	7.8	7.8					
	B	6	4					
C	4.5	4.5						
<p>H600C-T</p>	 <p>(28kg)</p>			Main circuit	Terminal screw	M12 bolt	-	
					Terminal dimensions	A	55	-
						B	16	-
				Operating circuit	Terminal screw	M4	M3.5	
Terminal dimensions	A	9	4					
	B	7.2	4					
C	5	4.5						

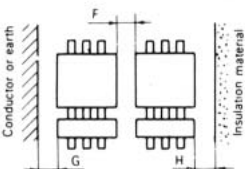
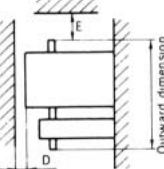
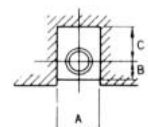
Dimensions	Minimum mounting space (mm)					Mounting space	Conductor or earth	Terminal section dimensions
	Type	D	E	F	G			
H100C-T H125C-T H150C-T	1	15	10	10	10			
H200C-T H250C-T	1	20	10	10	10			
H300C-T H400C-T	1	30	10	10	10			
H600C-T	1	50	10	10	10			

Reversible Electromagnetic Contactors without Enclosure

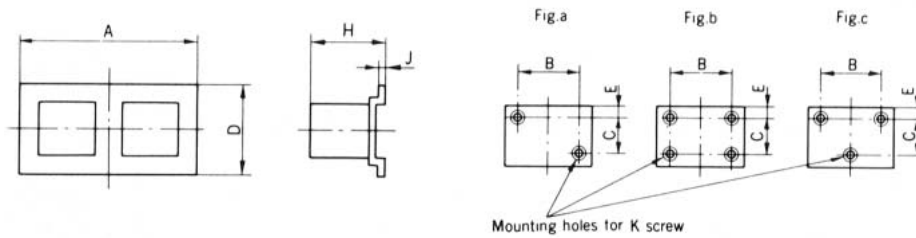

Type	Dimensions (mm)				Drilling plan (mm)					Weight (kg)
	A	D	H	J	Fig	B	C	E	K	
H10B-R	84	71.5	95.5	17	a	73	54	5.5	2-M4	0.62
H11-R	120	90	87.5	1.2	c	90	75	7.5	3-M4	0.73
H12-R	127	90	86	1.2	c	90	75	7.5	3-M4	0.65
H20-R	172	90	101.5	1.6	c	155	75	7.5	3-M4	1.2
H25-R	172	100	101.5	1.6	c	155	75	12.5	3-M4	1.3
H35-R	200	120	114	1.6	c	180	100	7.5	3-M5	2
H50-R	200	120	114	1.6	c	180	100	7.5	3-M5	2
H65C-R	200	120	123	1.6	c	180	100	7.5	3-M5	2.9
H80C-R	240	170	160	1.6	c	220	150	10	3-M6	5.0
H100C-R H125C-R	240	170	160	1.6	c	220	150	10	3-M6	5.1
H150C-R	280	200	171	2.3	c	260	150	10	3-M6	6.2
H200C-R H250C-R	330	290	198	3.2	c	300	260	15	3-M8	14
H300C-R H400C-R	385	300	244	3.2	c	340	270	15	3-M8	25
H600C-R	578	316	258	25	b	480	278	19	4-M10	53
H800C-R	578	380	258	25	b	480	278	51	4-M10	53

Reversible Electromagnetic Starters without Enclosure

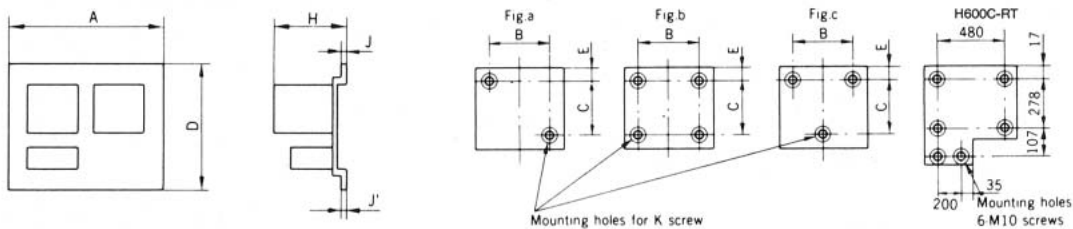

Type	Dimensions (mm)				Drilling plan (mm)					Weight (kg)
	A	D	H	J (J')	Fig.	B	C	E	K	
B) H10B-RT	84	128	95.5	17	a	73	54	5.5	2-M4	0.68
B) H11-RT	120	132	87.5	1.2	c	90	75	7.5	3-M4	0.82
B) H12-RT	127	132	86	1.2	c	90	75	7.5	3-M4	0.88
B) H20-RT	172	135	101.5	1.6	c	155	75	7.5	3-M4	1.45
B) H25-RT	172	144	101.5	1.6	c	155	75	12.5	3-M4	1.5
B) H35-RT	200	158	114	1.6	c	180	100	7.5	3-M5	2.4
B) H50-RT	200	158	114	1.6	c	180	100	7.5	3-M5	2.4
H65C-RT	200	186	123	1.6	c	180	170	7.5	3-M5	3.1
H80C-RT	240	228	160	1.6	c	220	210	10	3-M6	5.8
H100C-RT H125C-RT	240	247	160	1.6	c	220	210	10	3-M6	6.4
H150C-RT	280	277	171	2.3	c	260	240	10	3-M6	9.2
H200C-RT H250C-RT	330	341	198	3.2	c	300	260	15	3-M8	18
H300C-RT H400C-RT	385	360	244	3.2	c	340	270	15	3-M8	30
H600C-RT	578	453	258	25	-	-	-	-	-	58

Electromagnetic Starters without Enclosure



B) SH35-T

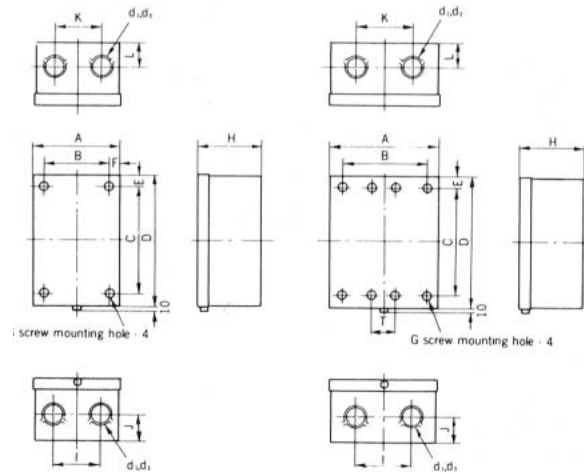

Color of enclosure
Munsell Code
5Y7/1

With plastic enclosure: SH8C-T, SH10C-T, SH10C-TB, SH11-T, SH11-TB (Other frames: steel enclosure)

With push-buttons: SH [] -TB

Frame	Type	Dimensions (mm)															Weight (kg)	
		A	B	C	D	E	F	G	H	I	J	K	L	T	d ₃	d ₄		
8C	B) SH8C-T																	0.59
10C	B) SH10C-T, B) SH10C-TB	85	65	140	165	12.5	7.5	M4 × 4	112	35	25	35	25	-	22	-	0.59	
11	B) SH11-T, B) SH11-TB																0.64	
20	B) SH20-T, B) SH20-TB	110	75	140	175	17.5	17.5	M5 × 4	114	35	30	35	30	-	22	-	1.5	
25	B) SH25-T, B) SH25-TB																2.7	
35	B) SH35-T, B) SH35-TB	150	105	210	255	22.5	22.5	M5 × 4	130	50	40	50	40	-	22	28	3.3	
50	B) SH50-T, B) SH50-TB																3.4	
65C	SH65C-T	206	160	290	336	23	23	M6 × 4	165	100	80	100	100	-	35	45	4.6	
80C	SH80C-T																5.1	
100C	SH100C-T	235	185	385	435	25	25	M8 × 4	200	120	90	120	105	-	45	52	7.5	
125C	SH125C-T																12	
150C	SH150C-T																13	
200C	SH200C-T	285	185	385	560	88	50	M8 × 4	225	120	95	120	120	-	55	65	14	
250C	SH250C-T																14.5	
300C	SH300C-T																25	
400C	SH400C-T	340	208	515	690	63	66	M10 × 4	258	160	107	160	107	-	62	78	25	
600C	SH600C-T	603	500	800	950	75	50	M12 × 4	400	280	202	280	202	-	100	120	55	
10B	B) SH10B-RT	110	75	140	175	17.5	17.5	M5 × 4	114	35	30	35	30	-	22	-	1.5	
11	B) SH11B-RT	160	130	135	167	16	15	M4 × 4	97	80	25	100	25	-	22	-	2.0	
20	B) SH20-RT	195	160	140	175	17.5	17.5	M5 × 4	116.5	80	30	120	30	-	22	-	2.5	
25	B) SH25-RT																4.5	
35	B) SH35-RT	235	190	210	255	22.5	22.5	M5 × 4	130	120	40	140	40	-	22	28	5.4	
50	B) SH50-RT																5.6	
65C	SH65C-RT	340	270	290	336	23	35	M6 × 4	165	100	80	100	100	-	35	45	8.5	
80C	SH80C-RT																10.5	
100C	SH100C-RT	415	365	385	435	25	25	M8 × 4	211	120	90	120	105	-	45	52	13	
125C	SH125C-RT																24	
150C	SH150C-RT																24	
200C	SH200C-RT	460	365	385	560	88	48	M8 × 4	225	120	95	120	120	-	55	65	29	
250C	SH250C-RT																29	
300C	SH300C-RT																53	
400C	SH400C-RT	604	474	515	690	64	58	M10 × 8	258	160	107	160	107	58	62	78	53	
600C	SH600C-RT	973	870	800	950	75	50	M12 × 8	400	280	202	208	202	110	100	120	115	

6. THERMAL OVERLOAD RELAYS

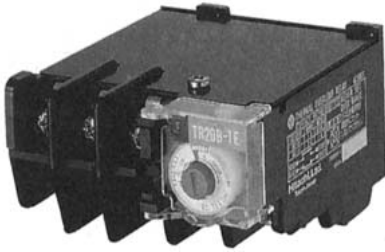

TR20B-1E

6.1 Features

1. IEC Standard Satisfied
These thermal overload relays conform to the IEC Standard, and provide perfect motor protection.
2. Automatic and manual reset
Automatic and manual reset can be easily set with a screwdriver.
3. Easy to Use
All controls are located on the front.
A trip indicator is provided.

Type

- 1E Thermal Overload Relay...standard relay with overload protection
- 2E Thermal Overload Relay...relay with overload and single phasing protection (same size as 1E relay)

6.2 Construction

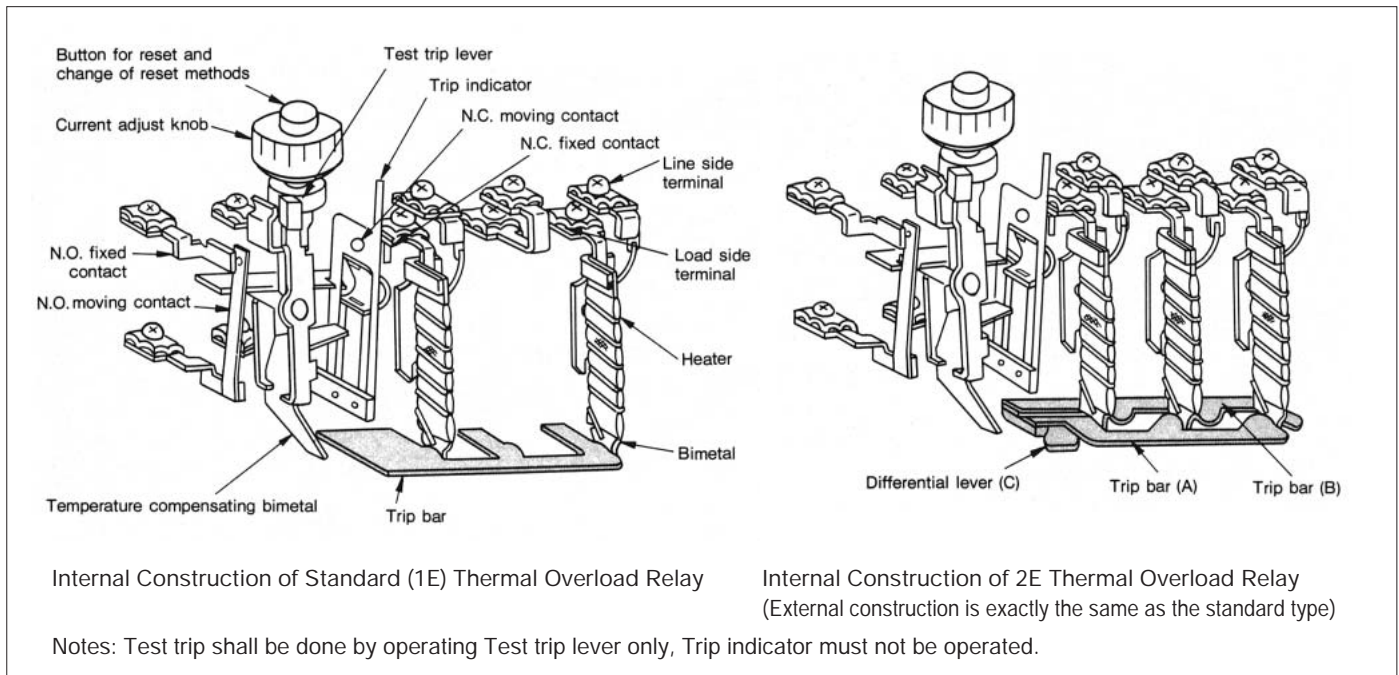

2E THERMAL OVERLOAD RELAY OPERATING MECHANISM

The bending difference between on-phase and off-phase bimetals is available for protection of single phase failure.

Three phase action	Trip bar A, trip bar B and differential lever C move to the left as one unit as if they were one trip bar, and open the contact. This movement is same as that of the conventional thermal overload relay.
Single phase action	Trip bar B does not move due to the off-phase bimetal and trip bar A only moves to the left. At this movement, the differential lever C revolves counter-clock-wise and opens the contact.

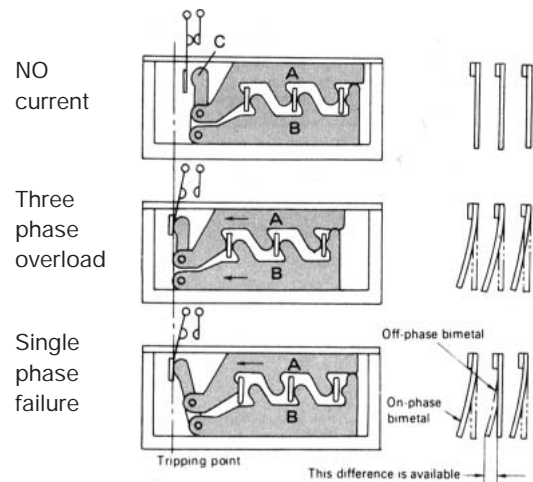

6.3 Tripping Characteristics

1E THERMAL OVERLOAD RELAYS

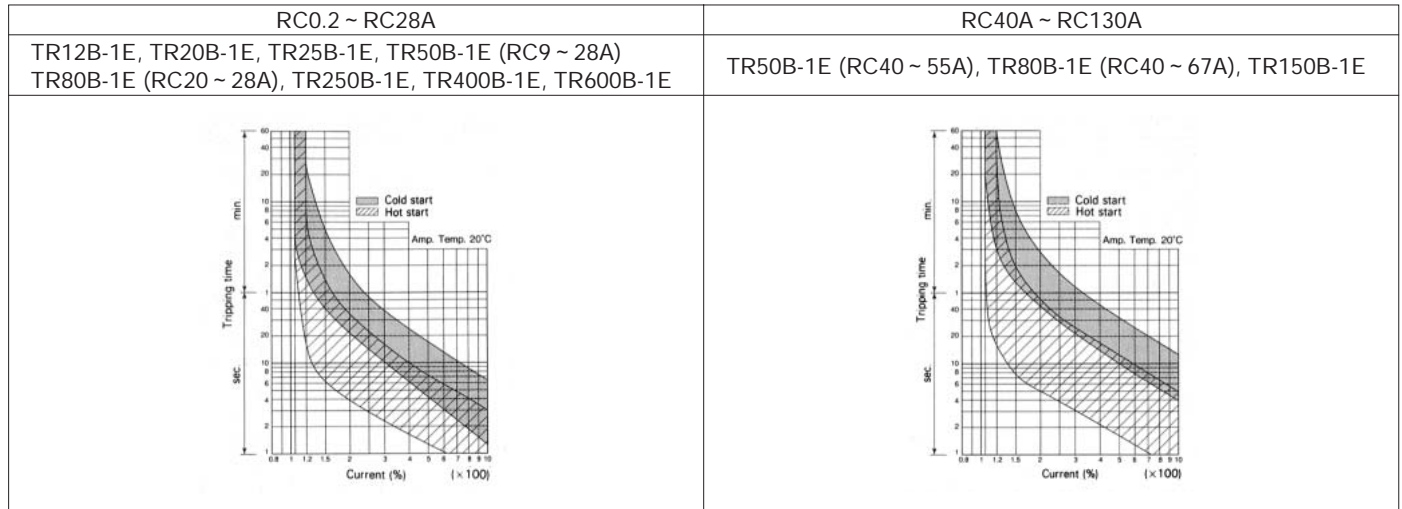

2E THERMAL OVERLOAD RELAYS

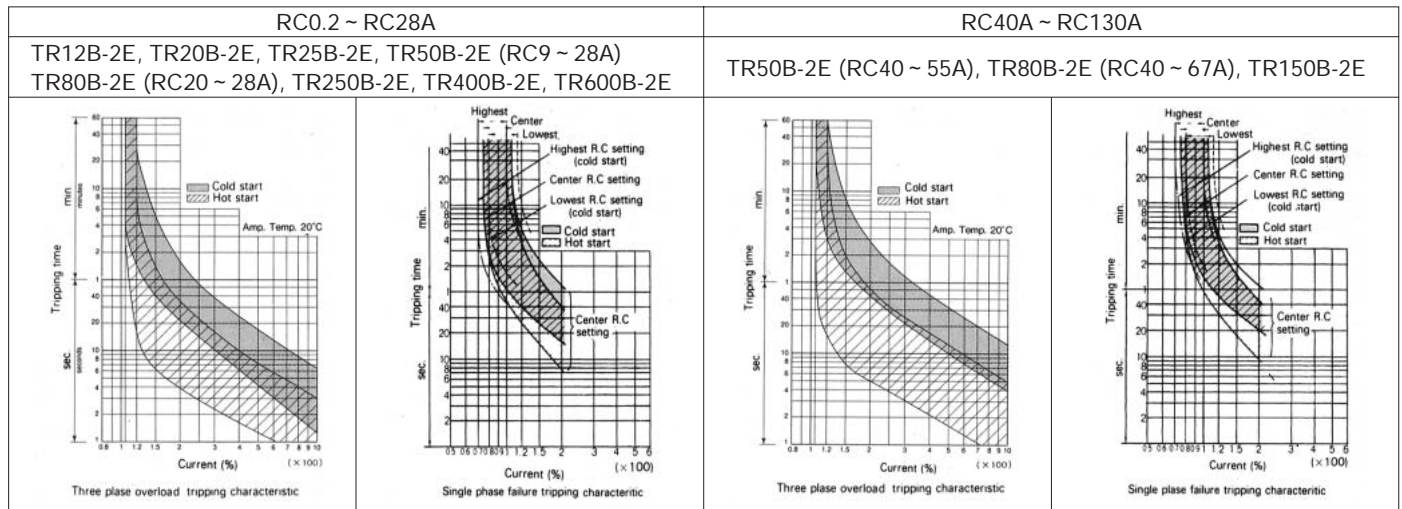

Cold Start: When overcurrent flows in a start where the thermal relay bimetals are not affected by current.

Hot Start: When overcurrent flows where the thermal relay bimetals are heated by current during motor running or restart.

Ambient Temperature Characteristics

The tripping characteristics are approximately constant under any ambient temperature so that compensating calculation is not necessary.

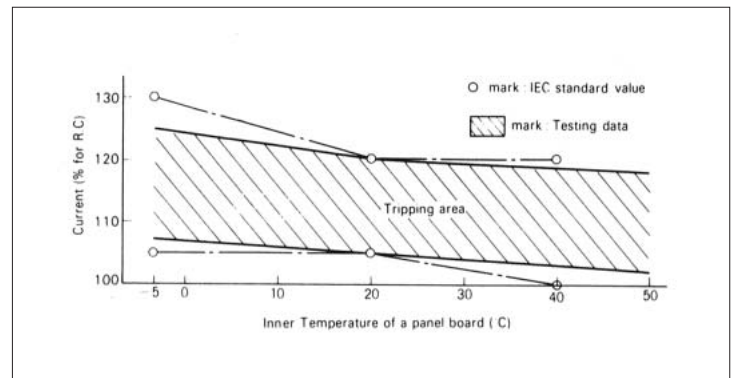

6.4 Application

Standard (1E) Thermal Overload Relay

HITACHI three phase squirrel-cage motor 4P for general purpose						Thermal overload relay			
						RC(A)		Applicable range for each type	
500V 50Hz	400V 50Hz (60Hz)	380V 50Hz	200V 50Hz (60Hz)	Center value	Adjustable range				
				0.2	0.16 ~ 0.24	TR12B-1E TR20B-1E			
				0.3	0.22 ~ 0.38				
				0.5	0.38 ~ 0.62				
				0.8	0.6 ~ 0.1				
0.4kW 1.0A	0.4kW 1.1A(1.0A)	0.4kW 1.3A	0.2kW 1.2A(1.1A)	1.2	0.9 ~ 1.5	TR12B-1E TR20B-1E			
0.75kW 1.5A			0.3kW 1.6A(1.5A)	1.4	1.1 ~ 1.8				
1.5kW 2.6A	0.75kW 1.9A(1.7A)	0.75kW 2.0A	0.4kW 2.3A(2.0A)	2.4	1.7 ~ 2.9				
2.2kW 3.7A	1.5kW 3.3A(3.0A)	1.5kW 3.5A	0.75kW 3.5A(3.2A)	3.8	2.8 ~ 4.4				
	2.2kW 4.5A(4.2A)	2.2kW 4.8A		5	4 ~ 6	TR12B-1E TR20B-1E			
3.7kW 5.8A	3.7kW 7.2A(7.0A)	3.7kW 7.5A	1.5kW 6.5A(6.0A)	6.8	5 ~ 8				
5.5kW 8.4A			2.2kW 9.0A(8.5A)	9	7 ~ 11				
7.5kW 11.5A	5.5kW 11.5A(10.5A)	5.5kW 11A		11	9 ~ 13				
11kW 16A	7.5kW 14A(13.5A)	7.5kW 14.5A	3.7kW 14.5A(14A)	15	12 ~ 18	TR12B-1E TR20B-1E			
15kW 22A	11kW 20A(19.5A)	11kW 21A	5.5kW 23A(21A)	20	16 ~ 24				
				22	18 ~ 26				
18.5kW 27A	15kW 26A(26A)	15kW 28A	7.5kW 28A(27A)	28	22 ~ 34	TR12B-1E TR20B-1E			
22kW 32A	18.5kW 34A(32A)	18.5kW 35A	11kW 42A(40A)	40	32 ~ 48				
30kW 42A	22kW 39A(37A)	22kW 42A		40	32 ~ 48				
				55	45 ~ 65				
37kW 52A	30kW 55A(52A)	30kW 55A	15kW 55A(52A)	55	45 ~ 65	TR12B-1E TR20B-1E			
	37kW 68A(65A)	37kW 68A	18.5kW 68A(65A)	67	55 ~ 80				
	45kW 80A(80A)	45kW 85A	22kW 82A(78A)	80	65 ~ 95				
	55kW 98A(95A)	55kW 100A	30kW 110A(105A)	105	90 ~ 120				
	75kW 130A(130A)		37kW 135A(130A)	130	110 ~ 150	TR12B-1E TR20B-1E			
	90kW 160A(155A)		45kW 165A(160A)	1.4(140)	(110 ~ 180)				
	110kW 190A(185A)		55kW 195A(190A)	2.4(240)	(170 ~ 290)				
	132kW 225A(220A)		75kW 260A(260A)	3.8(380)	(280 ~ 440)				
			90kW 320A(310A)			TR12B-1E TR20B-1E			
			110kW 380A(370A)						
			132kW 450A(440A)	5(500)	(400 ~ 600)				

- Notes: 1) Be sure to adjust the setting current on the adjusting knob of the thermal overload relay to the rated current value (RC) of the motor employed (The setting current must be within indicated value.).
2) The figure in the parenthesis of center value (RC) is the current of primary side.

STANDARDS FOR THERMAL OVERLOAD RELAY

The standard type (1E) thermal overload relay and 2E thermal overload relay conform to the JIS, JEM and IEC standards in the right table.

Notes:

Values (%) in the table indicate multiples against the rated current.

Standard	JIS C8201-4-1			JEM 1356			IEC 60947-4-1			
	Ambient temperature	Non-operation	Operation	Ambient temperature	Non-operation	Operation	Ambient temperature	Non-operation	Operation	
Overload relay operation	Standard type and 2E thermal overload relays	40	100%	120% within 2hours	40	100%	120% within 2hours	40	100%	120% within 2hours
		20	105%	120% within 2hours	20	100%	120% within 2hours	20	105%	120% within 2hours
		- 5	105%	130% within 2hours	- 5	100%	130% within 2hours	- 5	105%	130% within 2hours
		20	100%	150% within 2minutes(Class10A) within 4minutes(Class10) within 8minutes(Class20)	20	100%	200% within 2minutes	20	100%	150% within 2minutes(Class10A) within 4minutes(Class10) within 8minutes(Class20)
Phase-failure operation	Standard type thermal overload relays	-	-	-	20	3 elements 100% 2 elements 100%(2 poles)	132%(2 poles only) 144%(1 pole only)	20	105% (All poles)	1 pole 0% and 132% to balance poles
		20	100%(2 poles) 90%(1 pole)	115%(2 poles) 0%(1 pole)	within 2 hours	20	90%(1 pole)	115%(2 poles) 0%(1 pole)	within 2 hours	

Standard (2E) Thermal Overload Relay

HITACHI three phase squirrel-cage motor 4P for general purpose					Thermal overload relay		
					RC (A)		Applicable range for each type
500V 50Hz	400V 50Hz (60Hz)	380V 50Hz	200V 50Hz (60Hz)	Center value	Adjustable range		
				0.2	0.16 ~ 0.24	TR12B-2E TR20B-2E	
				0.3	0.24 ~ 0.36		
				0.4	0.32 ~ 0.48		
				0.5	0.4 ~ 0.6		
				0.6	0.5 ~ 0.7		
				0.8	0.7 ~ 0.9		
0.4kW 1.0A				1.0	0.8 ~ 1.2		
	0.4kW 1.1A(1.0A)	0.4kW 1.3A	0.2kW 1.2A(1.1A)	1.2	1.0 ~ 1.4		
0.75kW 1.5A			0.3kW 1.6A(1.5A)	1.4	1.1 ~ 1.7		
	0.75kW 1.9A(1.7A)			1.8	1.4 ~ 2.2		
1.5kW 2.6A		0.75kW 2.0A	0.4kW 2.3A(2.0A)	2.4	2.0 ~ 2.8		
				3.0	2.4 ~ 3.6		
2.2kW 3.7A	1.5kW 3.3A(3.0A)	1.5kW 3.5A	0.75kW 3.5A(3.2A)	3.8	3.0 ~ 4.5		
3.7kW 5.8A	2.2kW 4.5A(4.2A)	2.2kW 4.8A		5.0	4.0 ~ 6.0		
	3.7kW 7.2A(7.0A)	3.7kW 7.5A	1.5kW 6.5A(6.0A)	6.8	5.5 ~ 8.0		
5.5kW 8.4A			2.2kW 9.0A(8.5A)	9.0	7.0 ~ 11		
7.5kW 11.5A	5.5kW 11.5A(10.5A)	5.5kW 11A		11	9 ~ 13		
11kW 16A	7.5kW 14A(13.5A)	7.5kW 14.5A	3.7kW 14.5A(14A)	15	12 ~ 18		
15kW 22A	11kW 20A(19.5A)	11kW 21A	5.5kW 23A(21A)	20	16 ~ 24		
				22	18 ~ 26		
18.5kW 27A	15kW 26A(26A)	15kW 28A	7.5kW 28A(27A)	28	22 ~ 34	RC22A = TR25B-2E only	
22kW 32A	18.5kW 34A(32A)	18.5kW 35A	11kW 42A(40A)	40	32 ~ 48		
30kW 42A	22kW 39A(37A)	22kW 42A		40	32 ~ 48		
				55	46 ~ 65		
37kW 52A	30kW 55A(52A)	30kW 55A	15kW 55A(52A)	55	45 ~ 65		
	37kW 68A(65A)	37kW 68A	18.5kW 68A(65A)	67	55 ~ 80		
	45kW 80A(80A)	45kW 85A	22kW 82A(78A)	80	65 ~ 95		
	55kW 98A(95A)	55kW 100A	30kW 110A(105A)	105	90 ~ 120		
	75kW 130A(130A)		37kW 135A(130A)	130	110 ~ 150		
	90kW 160A(155A)		45kW 165A(160A)	1.4(140)	(110 ~ 170)	TR20B-2E with CT (ratio 100:1)	
	110kW 190A(185A)		55kW 195A(190A)	1.8(180)	(140 ~ 220)		
	132kW 225A(220A)		75kW 260A(260A)	2.4(240)	(200 ~ 280)		
			90kW 320A(310A)	3.0(300)	(240 ~ 360)		
			110kW 380A(370A)	3.8(380)	(300 ~ 450)		
			132kW 450A(440A)	5(500)	(400 ~ 600)		









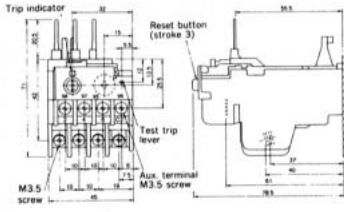

- Remarks: 1) Be sure to adjust the setting current on the adjusting knob of the thermal overload relay to the rated current value (RC) of the motor employed (The setting current must be within indicated value.).
 2) The figure in the parenthesis of center value (RC) is the current of primary side.

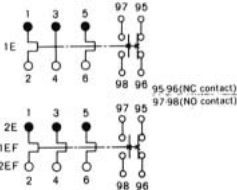
APPLICATION FOR SINGLE-PHASE MOTOR

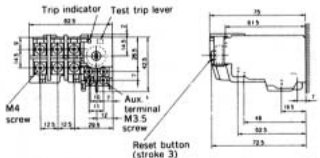
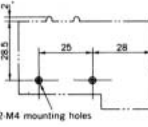
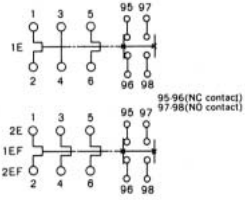
Single-phase motor 100V		Standard type (1E) thermal overload relay			Thermal overload relay application method
Capacity (kW)	Hitachi single-phase motor current (A) (Reference)	Thermal overload relay RC value (A)		Type application range	
		Center value	Setting current width		
0.035	1.2 ~ 1.4	1.4	1.1 ~ 1.8	TR12B-1E(RC 1.4~11.4) TR20B-1E(RC 1.4~15A)	
0.065	2.2 ~ 2.5	2.4	1.7 ~ 2.9		
0.1	3.0 ~ 3.8	3.8	2.8 ~ 4.4		
0.2	4.1 ~ 6.3	6.8	5 ~ 8		
0.25	5.4 ~ 6.7				
0.3	6.4 ~ 7.1				
0.4	5.8 ~ 9.6	9	7 ~ 11		
0.55	8 ~ 9.5				
0.75	10.5 ~ 15.5	11	9 ~ 13		
		15	12 ~ 18		

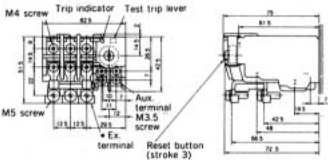
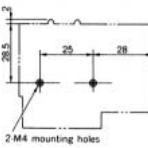
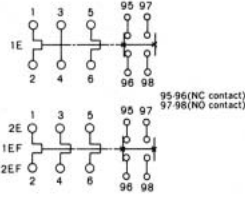
Notes: Set the current value of the thermal overload relay with adjusting knob after confirming the current of the applying motor.

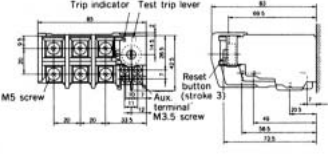
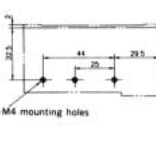
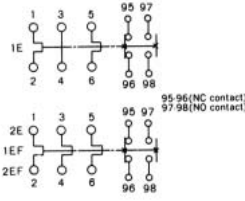

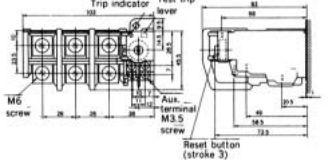
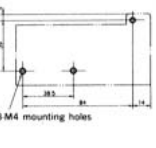
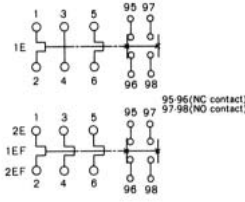

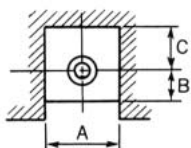

6.5 Appearance and Dimensions

Appearance	Dimensions (mm) (Product weight)	Drilling plan	Contact arrangement	Terminal section dimensions (mm)			
 TR12B-1E TR12B-2E TR12B-1EF TR12B-2EF	 (0.1kg)			Main circuit	Terminal screw	M3.5	
					Terminal dimensions	A	7.8
B	6						
C	4.5						
Operating circuit				Terminal screw	M3.5		
					Terminal dimensions	A	7.8
						B	4
C	4.5						
 TR20B-1E TR20B-2E TR20B-1EF TR20B-2EF	 (0.15kg)			Main circuit	Terminal screw	M4	
					Terminal dimensions	A	9 (9)
B	5 (7.4)						
C	5 (5)						
Operating circuit				Terminal screw	M3.5		
					Terminal dimensions	A	7.8
						B	4
C	4.5						
 TR25B-1E TR25B-2E TR25B-1EF TR25B-2EF	 (0.17kg)			Main circuit	Terminal screw	M5 (M4)	
					Terminal dimensions	A	10 (9)
B	6 (7.4)						
C	8.5 (5)						
Operating circuit				Terminal screw	M3.5		
					Terminal dimensions	A	7.8
						B	4
C	4.5						
 TR50B-1E TR50B-2E TR50B-1EF TR50B-2EF	 (0.25kg)			Main circuit	Terminal screw	M5	
					Terminal dimensions	A	13 (13)
B	6.5 (10)						
C	7 (7)						
Operating circuit				Terminal screw	M3.5		
					Terminal dimensions	A	7.8
						B	4
C	4.5						
 TR80B-1E TR80B-2E TR80B-1EF TR80B-2EF	 (0.36kg)			Main circuit	Terminal screw	M6	
					Terminal dimensions	A	16.5 (16.5)
B	8.5 (10.5)						
C	5 (9)						
Operating circuit				Terminal screw	M3.5		
					Terminal dimensions	A	7.8
						B	4
C	4.5						

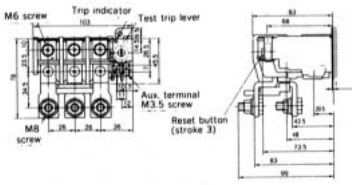
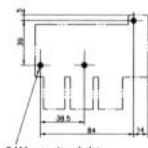
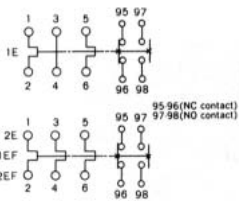
TERMINAL SECTION DIMENSIONS

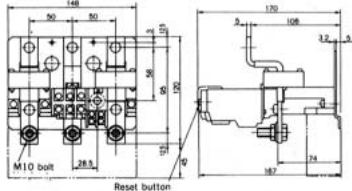
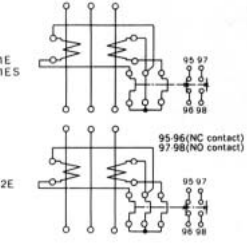
Values shown in parenthesis in the main circuit terminal dimensions are values of the power side.

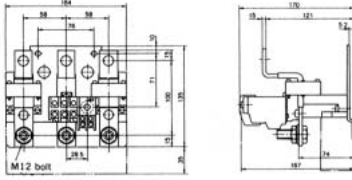
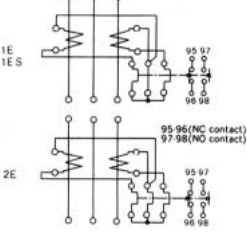

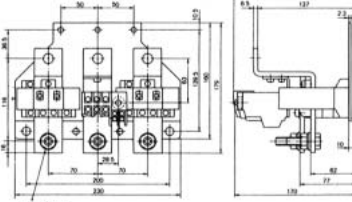
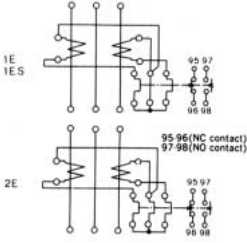
Appearance	Dimensions (mm) (Product weight)	Drilling plan	Contact arrangement	Terminal section dimensions (mm)	
 <p>TR150B-1E TR150B-2E TR150B-1EF TR150B-2EF</p>	 <p>(0.37kg)</p>	 <p>3 M4 mounting holes</p>		Main circuit	Terminal screw: M8 (M6)
				Terminal dimensions	A: 22 (16.5) B: 8 (10.5) C: 11 (9)
 <p>TR250B-1E TR250B-2E TR250B-1ES</p>	 <p>(2.0kg)</p>	<p>For mounting to H200, H250</p>		Main circuit	Terminal screw: M10 bolt
				Terminal dimensions	A: 37 B: 12.5 C: 16
 <p>TR400B-1E TR400B-2E TR400B-1ES</p>	 <p>(2.0kg)</p>	<p>For mounting to H300, H400</p>		Main circuit	Terminal screw: M12 bolt
				Terminal dimensions	A: 44 B: 15 C: 20
 <p>TR600B-1E TR600B-2E TR600B-1ES</p>	 <p>(5.0kg)</p>	<p>For mounting to H600</p>		Main circuit	Terminal screw: M12 bolt
				Terminal dimensions	A: 55 B: 16 C: 28
				Operating circuit	Terminal screw: M3.5
				Terminal dimensions	A: 7.8 B: 4 C: 4.5

Notes: 1. Changing Reset Method
Normally, relay is set in manual reset.
The change to automatic reset is done easily as shown in the following diagram.

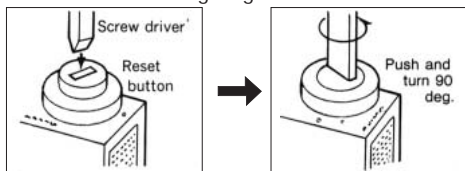

MANUAL RESET

AUTOMATIC RESET

2. Opening Cover for Current Adjusting Knob

Turn protection cover by pulling up the projection with a finger.

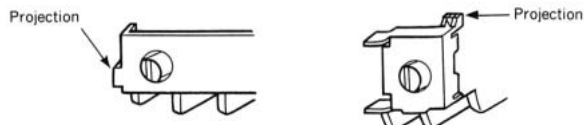

Protection cover (TR12B)

Protection cover (TR20B ~ TR600B)

7. ELECTROMAGNETIC STARTERS WITH 2E THERMAL OVERLOAD RELAY (OVERLOAD AND PHASE-FAILURE PROTECTION)

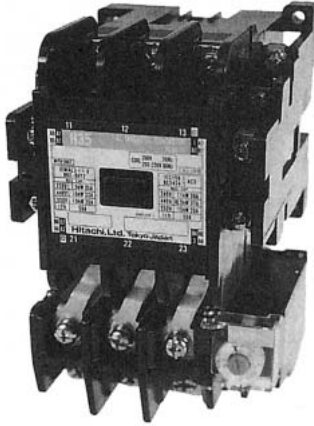

B) H35-TK

The 2E thermal overload relay has the following features in comparison to the conventional semiconductor type 2E relay.

FEATURES

1. The size has been drastically reduced so that the mounting area is only about 40% and the weight about 30% of the conventional 2E relay.
2. Price has also been drastically reduced to about 40%.
3. Mounting and wiring have been facilitated.

ELECTROMAGNETIC CONTACTOR

The electromagnetic contactor which has high efficiency and long life is used.

2E THERMAL OVERLOAD RELAY

With this design, a sensitive phase-failure protection function has been added to the 3-element thermal overload relay. It is the smallest thermal overload relay available. Besides this, it possesses stabilized characteristics features and many merits such as independent installation capability, handling convenience, safety, etc.

7.1 Phase-Failure Protection Effect of 2E Thermal Overload Relays

In case of smaller capacity motors, 3-element thermal overload relay can protect the motor from burn-out due to phase-failure operation.

However, since motors above medium capacity have a tendency that due to the rotor construction, the temperature rises remarkably at time of phase-failure, 1E thermal overload relay cannot protect the motor.

Nevertheless, when the 2E thermal overload relay is used even in such a case, protection at time of phase-failure can be ensured as it will operate before the motor temperature becomes high, as shown in the table below, by the action of the built-in differential phase-failure detection mechanism (Please refer to page 31: the principle of the differential phase-failure detection mechanism.).

Operation	Thermal overload relay	Motor capacity (200V, kW)	Temperature rise of motor at thermal overload relay operation		
			0.5	1	1.5
Three-phase 	1E or 2E thermal overload relay	0.2 ~ 132	*The temperature rise at three-phase overload operation of each motor is made 1.		
Phase-failure 	1E thermal overload relay	0.75	[Bar chart showing temperature rise reaching 1.0]		
		3.7	[Bar chart showing temperature rise reaching 1.0]		
		11	[Bar chart showing temperature rise reaching 1.0]		
		55	[Bar chart showing temperature rise reaching 1.0]		
		132	[Bar chart showing temperature rise reaching 1.0]		
	2E thermal overload relay	0.75	[Bar chart showing temperature rise reaching 0.5]		
		3.7	[Bar chart showing temperature rise reaching 0.5]		
		11	[Bar chart showing temperature rise reaching 0.5]		
		55	[Bar chart showing temperature rise reaching 0.5]		
		132	[Bar chart showing temperature rise reaching 0.5]		
			The 2E thermal overload relay operates before the motor temperature becomes high.		

7.2 Appearance and Dimensions

Since dimensions are the same as the standard type electromagnetic starter (those without K at the end), see pages 26 to 28 for non-reversible type frames without enclosure and page 29 for

reversible type frames without enclosure. Moreover see page 30 for frames with enclosure.

8. DC OPERATED ELECTROMAGNETIC CONTACTORS

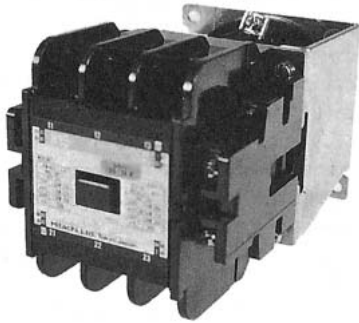

H35-G

FEATURES

The compact design drastically reduces the mounting space to the control panel.
 DC exciting type is noiseless.
 Direct input type without external resistors for models up to 65C frame.

8.1 Operating Principle of Double Coil

H80C-G ~ H125C-G		The double coil is a coil which has 2 coils, closing coil CC and holding coil HC are wound on the coil bobbin. In explaining the operation by the left diagram circuit, it becomes as below. (1) When BSa is closed, current flows as (\oplus) BSS BSa 52NC CC (\ominus) and only CC coil is excited and picked up. (2) When picked up, the changeover NC contact opens, and current flows as (\oplus) BSS 52NO HC CC (\ominus) and both coils of HC and CC are excited. After pick-up, the internal resistance of HC is large in comparison to that of CC so current decreases and watt loss of the coil is reduced.
Remarks : C.C. : Closing coil H.C. : Holding coil		H150C-G ~ H800C-G Change between closing coil (CC) and holding coil (HC) is controlled by the provided control circuit.

8.2 Dimensions

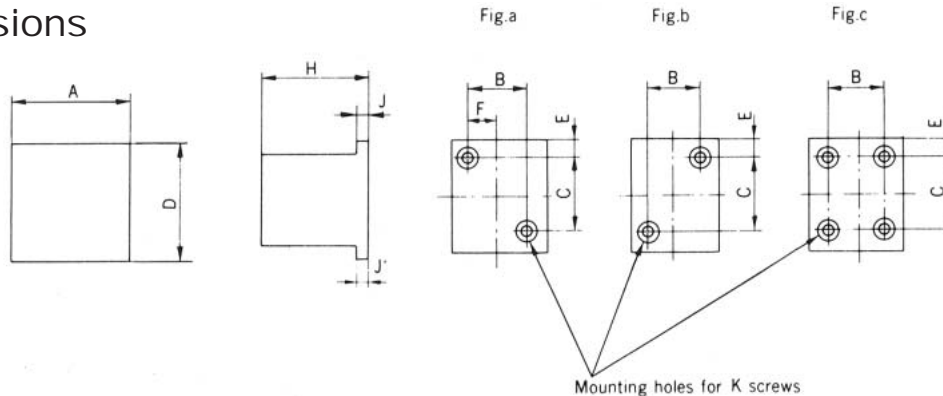

Type	Dimension (mm)				Drilling plan (mm)						Weight (kg)
	A	D	H	J (J')	Fig.	B	C	E	F	K	
H10-G	44	65	108	2.3	a	33	55	5	17	2-M4	0.5
H11-G	53	65	108	2.3	a	33	55	5	17	2-M4	0.58
H20-G	64	70	123	2.3	a	54	59	5.5	-	2-M4	1.02
H25-G	64	100	123	2.3	a	54	59	20.5	-	2-M4	1.08
H35-G H50-G	82	90	128.5	2.3	a	71	65	12.5	-	2-M4	1.7
H65C-G	88	106	147	2.3	a	71	65	20.5	-	2-M4	2.1
H80C-G H100C-G H125C-G	100 *(124)	136	154	17.5	b	84	110	13	-	2-M5	2.2
H150C-G	120 *(144)	153	165	17	b	100	130	11.5	-	2-M6	3.3
H200C-G H250C-G	138 *(162)	230	191	2.3	c	50	210	10	-	4-M8	5.5
H300C-G H400C-G	187 *(199)	240	225	3.2	c	60	220	10	-	4-M8	9.7
H600C-G	284	316	232	3.2	c	170	222	46	-	4-M10	22

* Auxiliary contacts 4NO3NC

** Auxiliary contacts 4NO4NC

9. LATCHED ELECTROMAGNETIC CONTACTORS

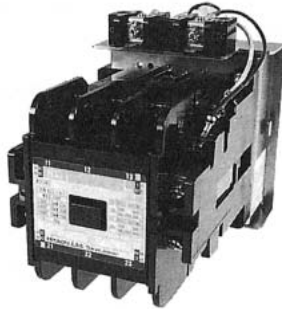

H35-TL

Features and Applications:

1. After the contact has been closed, the contactor has kept been in closed position mechanically, so that it cannot be released due to service interruption, momentary service interruption, voltage drop, etc. This contactor is most suitable such important circuits or memory circuits related to chemical plants, spinning machines, etc. which must be protected against its release particularly due to momentary service interruption or voltage drop.
2. Capable of being remote-controlled, and at ordinary times, free from power consumption of coil or humming. Ideal applications of the contactor are to distribution board circuits for facilities of buildings like hospitals, supermarkets, etc., automatic control circuits of street lights, motor load of display show-cases, etc. which are not often switched on and off or are continuously used for a long time.
3. In case of the reversible type, one with mechanical interlock can be manufactured. This is suitable for emergency power source changeover.
4. Self cut-off contact is equipped for both closing and tripping coils.
5. In an emergency, manual break is possible.

9.1 Explanation of Operation

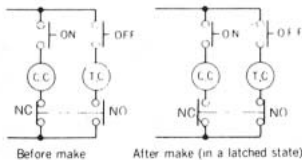

Explanation of Operation:

ON: Making by means of excitation of CC, which can be held mechanically. After making, the contact NO is in "ON" state, and the contact NC is in "OFF" state.

OFF: Releasing by means of excitation of TC. After release, the contact NO returns to "OFF", and the contact NC, to "ON". The contacts NO and NC are built in.

Note: The ON and OFF contacts should be interlocked.

9.2 Dimensions

Non-reversible type

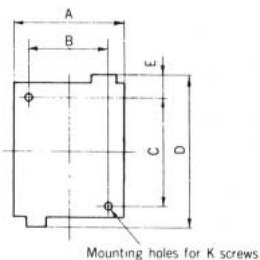

H10-L ~ H65C-L

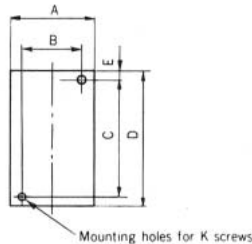

H80C-L ~ H150C-L

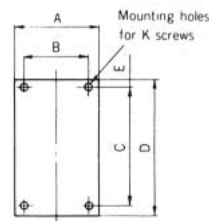

H200C-L ~ H600C-L

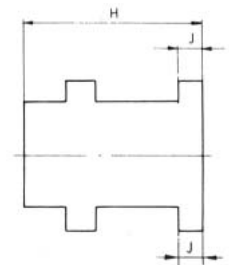

Type	Dimensions (mm)								Weight (kg)
	A	B	C	D	E	H	J (J')	K	
H10-L	49	33	55	65	5	130	10	M4 × 2	0.4
H11-L	55	33	55	65	5	130	10	M4 × 2	0.42
H20-L	72	54	59	108(122)	33.5(47.5)	127	42	M4 × 2	0.85
H25-L	72	54	59	113(127)	33.5(47.5)	127	42	M4 × 2	0.9
H35-L	88	71	65	116(130)	34.5(48.5)	139	45	M4 × 2	1.2
H50-L									
H65C-L	91	70	65	127(141)	34.5(48.5)	145	44	M4 × 2	1.65
H80C-L									
H100C-L	107	84	110	153(154)	25.5(26.5)	188	51	M5 × 2	2.7
H125C-L									
H150C-L	134	100	130	194	43.5	201	53	M6 × 2	4.0
H200C-L	154	115	185	235	30	225	36	M8 × 4	8.0
H250C-L									
H300C-L	170	60	320	340	10	227	5.5	M8 × 4	11.7
H400C-L									
H600C-L	270	170	322	389	46	235	7.7(5.5)	M10 × 4	28.0

Notes: () DC operated type H_{100C-L}-LG.

Reversible type

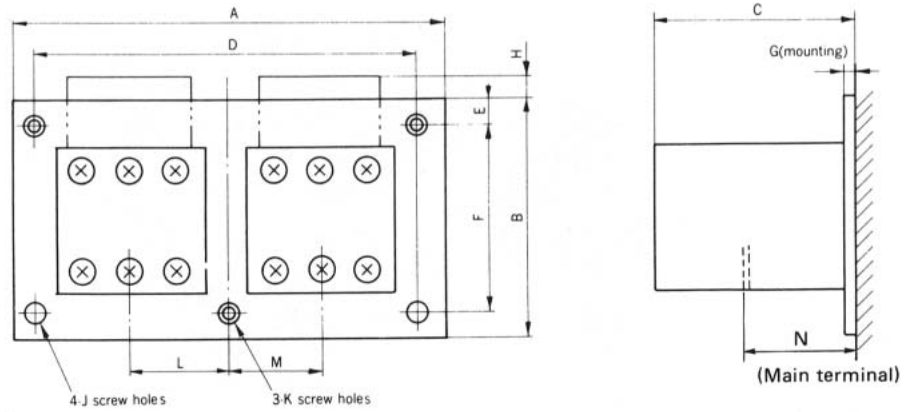

Type	A	B	C	D	E	F	G	H	J	K	L	M	N	Weight (kg)
H11-RL	120	90	135	90	7.5	75	1.2		M4		31	33	71	1.0
H20-RL	172	110	133	155	5	100	1.6	(13.5)	M4		41	41	95	2.0
H25-RL	172	110	133	155	5	100	1.6	(13.5)	M4		41	41	*96, 76	2.1
H35-RL	200	120	144	185	7.5	105	1.6	2(16)	M5		53.5	47.5	106	2.7
H50-RL											53.5	53.5	107	
H65C-RL	200	120	151	185	7.5	105	1.6	2(16)	M5		53.5	53.5	107	3.6
H80C-RL	240	170	194	220	10	150	1.6			M6	59.5	59.5	125	6.1
H100C-RL														
H125C-RL														
H150C-RL	280	226	207	260	10	206	2.3			M6	76.5	62.5	139	10
H200C-RL	330	290	232	300	15	260	3.2			M8	78.5	78.5	143	19
H250C-RL														
H300C-RL	360	380	251	320	10	360	9.2		M8		94	94	147	26
H400C-RL														
H600C-RL	540	413	258	480	18	378	25		M10		135	135	163	67

() DC operated type H_{11-RLG}.

*96 R, T, U, W phase

76 S, V phase

10. AUTOMATIC STAR-DELTA STARTERS (3-CONTACTORS TYPE)

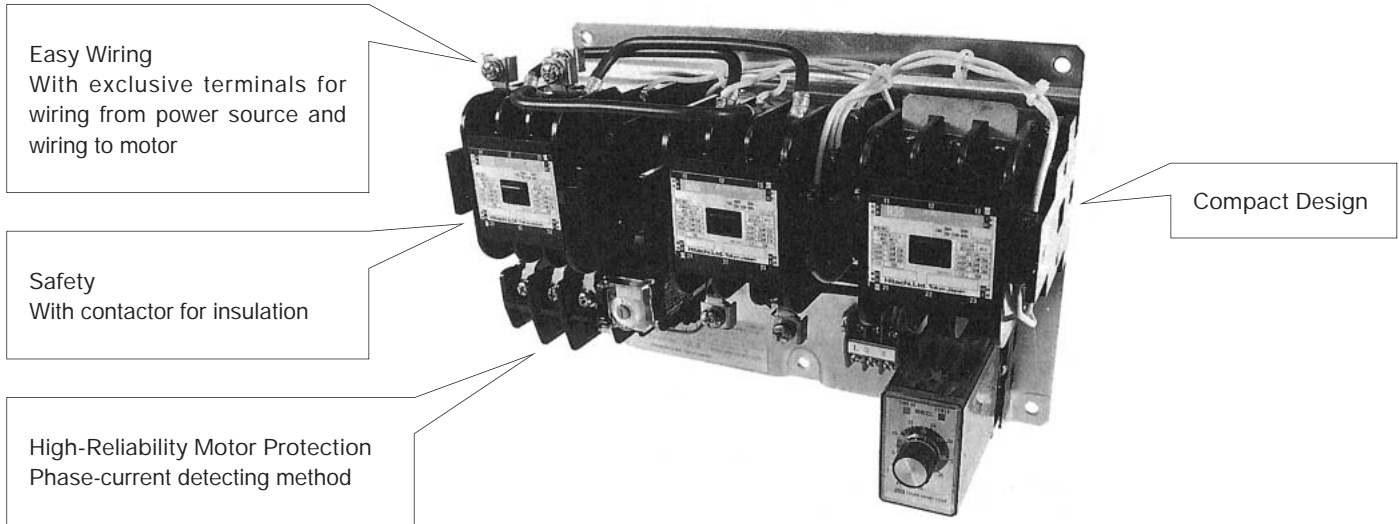

10.1 Ratings and Specifications

Voltage	Frame	Type		Motor capacity (AC3) (kW)	Components				
		Without enclosure	With enclosure		Contactor		Thermal overload relay		
					Insulation operation	Starting	Type	RC (A)	Adjustable range
220 ~ 240V	5	Y-5	SY-5	5.5	H20	H20	TR20B-1E	15	12 ~ 18
	7	Y-7	SY-7	7.5	H25	H20	TR20B-1E	15	12 ~ 18
	11	Y-11	SY-11	11	H35	H20	TR50B-1E	28	22 ~ 34
	15	Y-15	SY-15	15	H50	H25	TR50B-1E	28	22 ~ 34
	19	Y-19	SY-19	18.5	H50	H35	TR50B-1E	40	32 ~ 48
	22	Y-22	SY-22	22	H65C	H35	TR80B-1E	55	45 ~ 65
	30	Y-30	SY-30	30	H80C	H50	TR80B-1E	67	55 ~ 80
	37	Y-37	SY-37	37	H100C	H65C	TR150B-1E	80	65 ~ 95
	45	Y-45	SY-45	45	H125C	H65C	TR150B-1E	80	65 ~ 95
380 ~ 440V	55	Y-55	SY-55	55	H150C	H80C	TR150B-1E	105	90 ~ 120
	75	Y-75	SY-75	75	H200C	H125C	TR250B-1E	1.4 (140)	(110 ~ 180)
	11	Y4-11	SY4-11	11	H20	H20	TR20B-1E	9	7 ~ 11
	15	Y4-15	SY4-15	15	H25	H20	TR20B-1E	15	12 ~ 18
	19	Y4-19	SY4-19	18.5	H35	H25	TR50B-1E	20	16 ~ 24
	22	Y4-22	SY4-22	22	H50	H35	TR50B-1E	20	16 ~ 24
	30	Y4-30	SY4-30	30	H50	H35	TR50B-1E	28	22 ~ 34
	37	Y4-37	SY4-37	37	H65C	H50	TR80B-1E	40	32 ~ 48
	45	Y4-45	SY4-45	45	H65C	H65C	TR80B-1E	40	32 ~ 48
	55	Y4-55	SY4-55	55	H80C	H65C	TR80B-1E	55	45 ~ 65
	75	Y4-75	SY4-75	75	H100C	H80C	TR150B-1E	80	65 ~ 95
90	Y4-90	SY4-90	90	H125C	H100C	TR150B-1E	80	65 ~ 95	
110	Y4-110	SY4-110	110	H150C	H125C	TR150B-1E	105	90 ~ 120	

- Notes: 1. Set thermal overload relay to the figure - rated current of motor x 0.58 - before operation.
2. Timer is set at 10 seconds, do not set at more than 15 seconds to prevent mal-operation of thermal overload relay at starting.

10.2 Connection Diagram

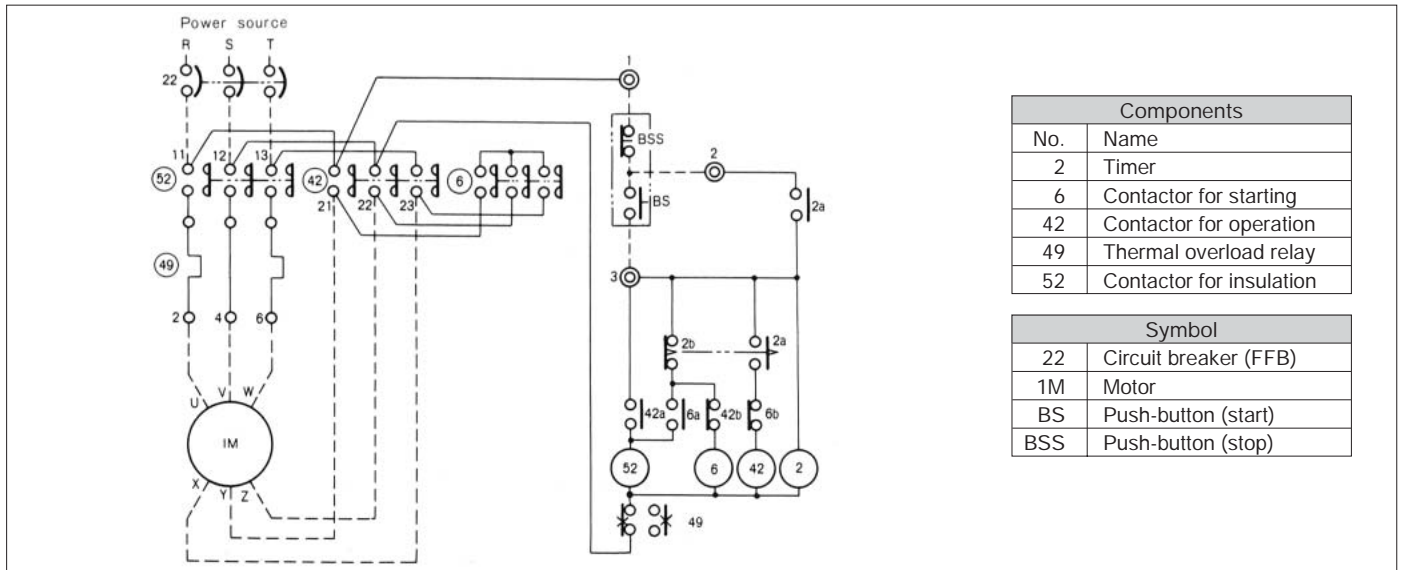

10.3 Dimensions

(1) Without enclosure

() In case of starter of 380 ~ 440V

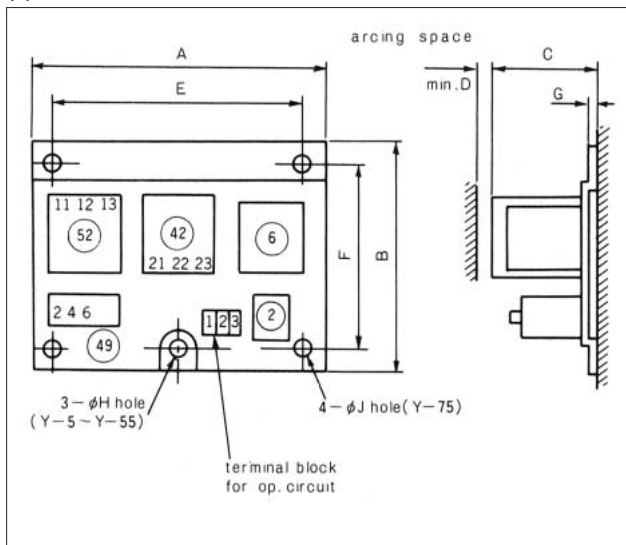

Frame	Dimensions (mm)				Drilling plan (mm)					Weight (kg)	
220 ~ 240V	380 ~ 440V	A	B	C	D	E	F	G	H		J
5.5	11	240	181 (200)	102 (101)	0	220	150	1.6	7	-	2.5 (3.8)
7.5	15										
11	18.5	280	200 (235)	114 (112)	0	260	180	200 (235)	7	-	4.2 (5.2)
15	22										
18.5	30										
22	37										
30	45	330	290	123 (122)	1	300	260	290	9	-	5.5 (6.5)
37	55										
45	55										
-	75	370	300	161 (124)	1	340	270	300	9	-	8.5 (10)
-	90										
55	110										
75	-	460	380	198	1	430	350	380	-	9	22

(2) With enclosure

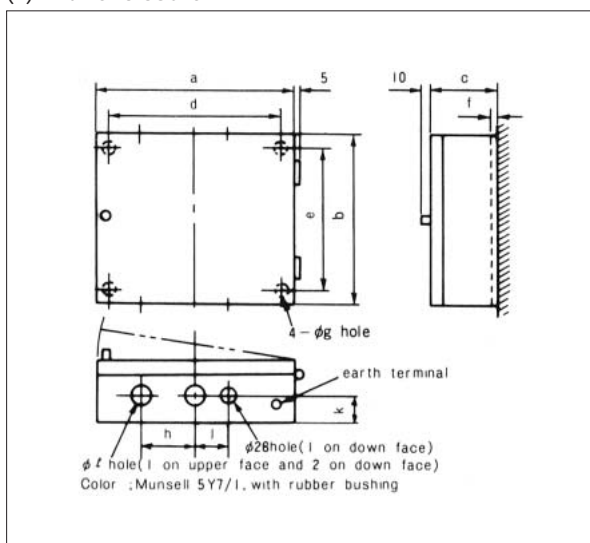

Frame	Dimensions (mm)			Drilling plan (mm)				Hole for wiring (mm)				Weight (kg)	
220 ~ 240V	380 ~ 440V	a	b	c	d	e	f	g	h	j	k		l
5.5	11	270	270	150	200	230	1.6	6	80	40	70	28	6.8 (8.1)
7.5	15												
11	18.5	320	320	150	250	250	1.6	7	100	60	80	42	9.7 (10.7)
15	22												
18.5	30												
22	37												
30	45	370	400	180	300	350	1.6	9	100	70	90	42	16.3 (17.8)
37	55												
45	55												
-	75	420	500	190	350	400	1.6	9	120	90	100	64	21.5 (23.0)
55	90												
55	110												
75	-	520	570	230	400	450	1.6	9	170	100	100	64	36.5

Notes: In case of starter with enclosure, with push-buttons and/or pilot lights can be supplied on request.

11. CONTACTOR RELAYS

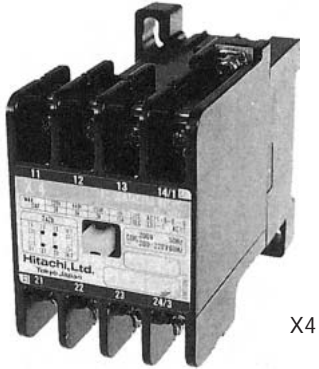

X4

FEATURES

1. Self-Up Screw
All models employ Hitachi's exclusive "self-up" screws with a seat for easy wiring.
2. High Reliability
The moving parts are made of thermoplastic resin to minimize wear. The rolling contacts of pure silver assure high contact reliability.

11.1 Application for the International Standards

Rated insulation voltage (V)	IEC	NEMA	BS	VDE
150	All types	All types	All types	All types
250				
300				
380				
500				
600				
660				

11.2 Return Spring Classification According to Contact Arrangement

Color of return spring / Type	non	red	blue	yellow
X3	-	3NO/2NO1NC	1NO2NC	-
X4	-	4NO/3NO1NC	2NO2NC	-
X5	5NO	4NO1NC	3NO2NC	2NO3NC
X6	-	6NO/5NO1NC	4NO2NC	3NO3NC
X8	8NO	-	6NO2NC	5NO3NC/4NO4NC

Notes: The conical coil spring is used for the return spring of X [] models.

11.3 Coil Ratings

Standard type (AC operation)

Designation	Rated operational voltage	Color of coil outer wrapping	Terminal code
AC100V	100V 50Hz/100 ~ 110V 60Hz	Yellow	
AC200V	200V 50Hz/200 ~ 220V 60Hz	White	
AC400V	400V 50Hz/400 ~ 440V 60Hz	Red	
-	Can be made within the range of 24V ~ 550V of other than those above.	Blue	

Notes: The latch's pick-up and tripping coil is of 30 seconds rating for both AC operation and DC operation.

DC operation

Designation and rated operational voltages

DC 24V, 48V, 100V, 110V, 200V, 220V

11.4 Contact Arrangement Diagram

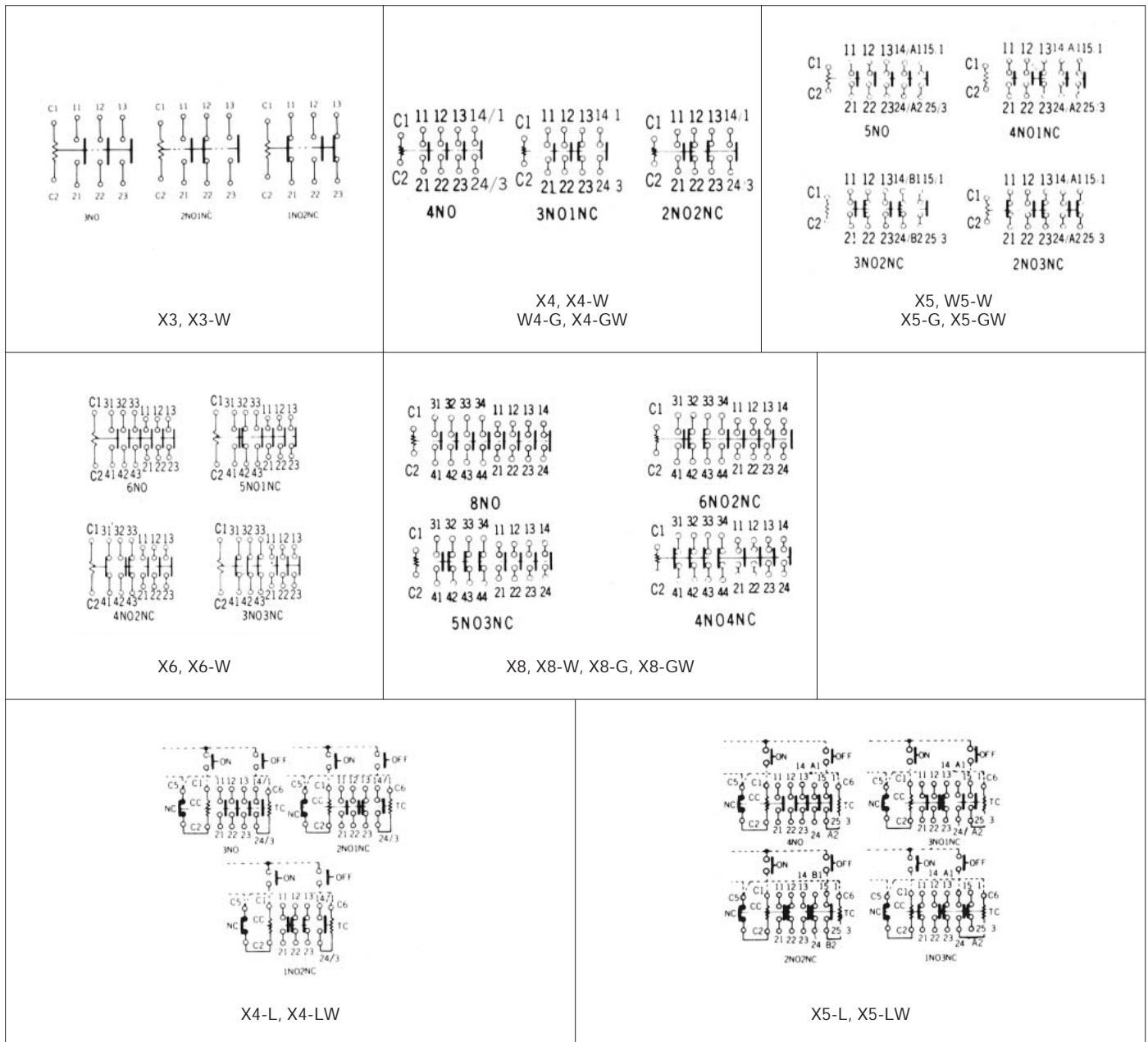

11.5 Dimensions and Weight

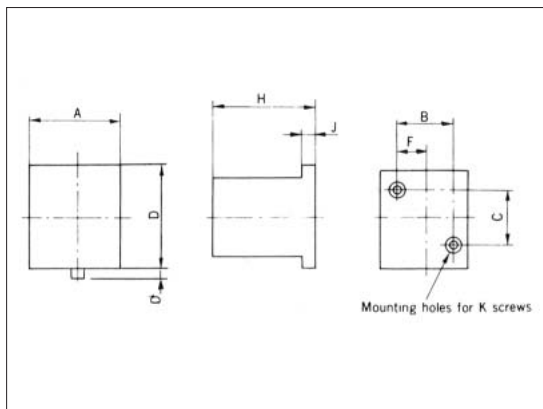

Type	Dimensions (mm)				Drilling plan (mm)				Weight (kg)
	A	D(D')	H	J	B	C	F	K	
X3, X3-W	36	65(65)	86	17.5	27	54	13.5	2-M4	0.25
X4, X4-W	43	65	82	10	33	55	16.5	2-M4	0.26
X5, X5-W	53	65	82	10	33	55	16.5	2-M4	0.29
X6, X6-W	36	65(65)	108	17.5	27	54	13.5	2-M4	0.29
X8, X8-W	43	65	105	10	33	55	16.5	2-M4	0.31
X4-G, X4-GW	44	65	107	2.3	33	55	17	2-M4	0.54
X5-G, X5-GW	53	65	108	2.3	33	55	17	2-M4	0.57
X8-G, X8-GW	44	65	130	2.3	33	55	17	2-M4	0.62
X4-L, X4-LW	49	65	130	10	33	55	16.5	2-M4	0.4
X5-L, X5-LW	55	65	130	10	33	55	16.5	2-M4	0.42

12. OPTIONS

12.1 Aux. Contact Block, Lamp Unit, Safety Cover and Mechanical Interlock Unit

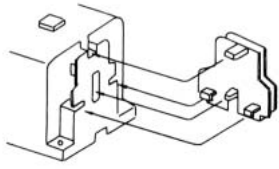
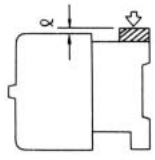
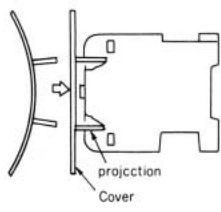
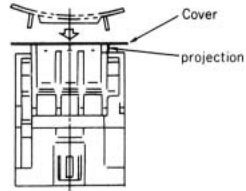
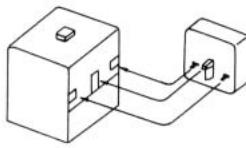
Item	Type	Rating	Applicable model	Mounting
Auxiliary contact block	AX-20	Rated current (AC11) 220V 2A 440V 1A	20, 25, 35, 50 frame	Example: AX-20 
	AX-65	Rated thermal current 1TH = 10A	65C frame	
	AX-80	Contact INO1NC	80C, 100C, 125C, 150C, 200C, 250C, 300C, 400C frame	
Lamp unit	LP-8	AC 100 ~ 220V	X3, X4, X5, X6, X8	 $l = 2 \sim 6\text{mm}$
			8C, 10C, 10B, 11, 12, 20, 25, 35, 50, 65C frame	
Safety cover	CV-8E	-	8C, 10C frame	 projection Cover
	CV-11E	-	11 frame	
	CV-20	-	20, 25 frame	
	CV-35	-	35, 50 frame	 Cover projection
	CV-65	-	65C frame	
	CV-80 CV-80T	-	80C, 100C, 125C frame	
	CV-150 CV-150T	-	150C frame	
	CV-200 CV-200T	-	200C, 250C frame	
	CV-300 CV-300T	-	300C, 400C frame	
	CV-600 CV-600T	-	600C frame	
CV-T20B	-	Thermal overload relay	TR20B frame	Secured to the cover of contactor by the provided screws.
CV-T50B	-		TR50B frame	
CV-T80B	-		TR80B frame	
Mechanical-Interlock unit	RI-20	-	Reversible type of 20, 25, 35 and 50 frame	
	RI-65		Reversible type of 65C frame	

12.2 Coil Surge Absorber



CS-8



H10C with CS-8

FEATURES

1. High reliability
2. Easy mounting to contactors and starters.

Generally, in the semiconductor circuits, an external noise may cause an unexpected malfunction. When operating the contactor, the coil generates a sharp surge voltage with the result that the peak voltage may reach higher than 4kV and the frequency higher than 5kHz.

This is radiated as noise to the outside, and it is difficult to prevent such noise even if a protective element is placed in the semiconductor circuit. Therefore, it is necessary to take measures against occurrence of noise from the coil. Connect coil surge absorber to the coil of the contactor in parallel. Then, the noise generated from the coil can be reduced.

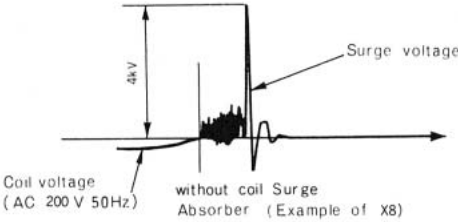

Surge voltage
4kV
Coil voltage (AC 200 V 50Hz)
without coil Surge Absorber (Example of X8)

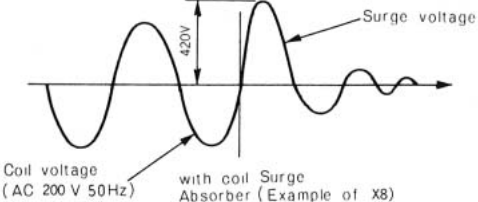

Surge voltage
420V
Coil voltage (AC 200 V 50Hz)
with coil Surge Absorber (Example of X8)

Ratings and Specifications

Type	Rated Voltage	Applicable models	Suppressed surge voltage (max.)
CS-8	AC 250V	X3, X4, X6, X8 H8C, H10C, H10B-R, H11, H12, H20, H25, H35, H50, H65C	600V Peak
CS-80		H80C, H100C, H125C	

Dimensions

CS-8, CS-80

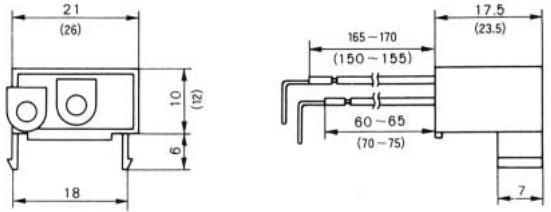

(): CS-80 (10g)

EXAMPLE OF CONNECTION

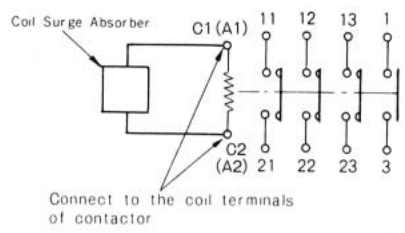

Connect to the coil terminals of contactor

Mounting and Dimensions

: Coil Surge Absorber

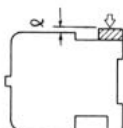
Type	Mounting	Dimensions
CS-8		$l = 2 \sim 6\text{mm}$
CS-80		

13. MAINTENANCE

Maintenance of Contacts

Contacts are sometimes subjected to blackening during usage due to oxide and sulfide films. However, use them as they are because they have absolutely no effect on the performance.

Maintenance of Coil

The allowable voltage regulation as specified in the standard is 85 ~ 110% of the rating.

When the voltage is too high, the impulse becomes great in case of closing and not only does it adversely affect each part but the coil becomes overheated and the coil life is shortened.

When the voltage is too low, a humming sound emanates from the magnet due to insufficient closing force of the magnet or a melting phenomenon occurs as the contacting force of the contactor weakens. Therefore, care should be taken that it is only

used in the allowable voltage range.

Tightening of Screws

Since screws will become loosened over a long period of time due to vibrations, etc., be sure to check screws of each section about once a month. When used with the screw loose, the section will overheat and cause troubles.

Contact Surface of Electromagnet

It will become the cause of beats when dust accumulates or rust forms on the contact surface.

When dust accumulates on the contact surface:

Clean the surface by wiping with a cloth.

When rust forms on the contact surface:

Place sandpaper on a flat table and rub the rusted contact surface lightly and evenly on the sandpaper with the rusted surface facing downward.

Replacement Method of Contact

(Example 1) Case of H20

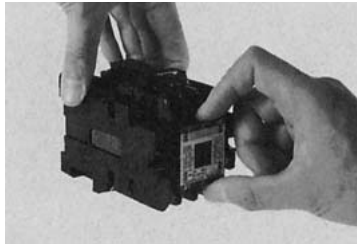

Remove the cover.

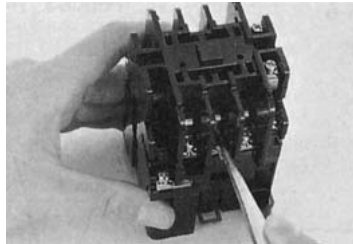

Pull out the moving contact with tweezers.

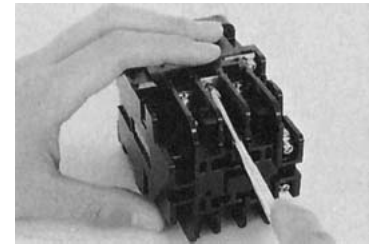

Replace the fixed contact with a screwdriver.

(Example 2) Case of H150C

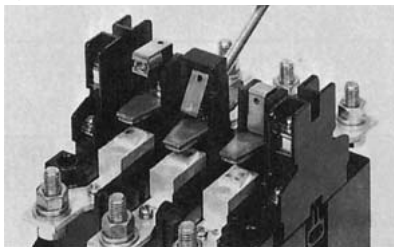

Remove the cover and turn the spring holder.

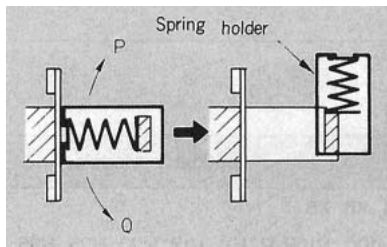

Turn the spring holder with fingers or a screwdriver by pushing to the P or O direction.

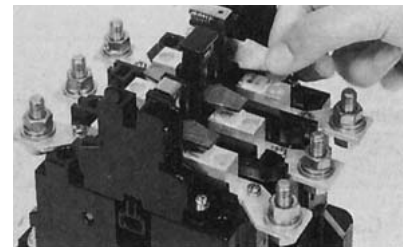

The moving contact can be removed when turned slightly. Remove the fixed contact with a screwdriver.

Replacement of Coil

(Example 1) Case of H20

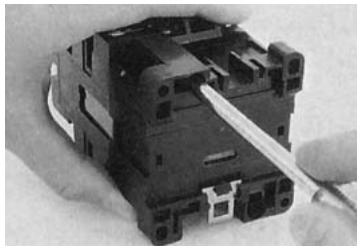

Remove case.



Remove the coil and replace with a new one.

Notes: In reassembly, turn the spring holder completely back to its former position.

(Example 2) Case of H150C

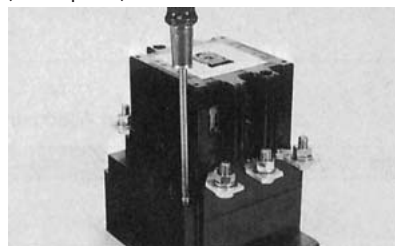

Ⓐ1) Loose screws securing Insulating cover to case.

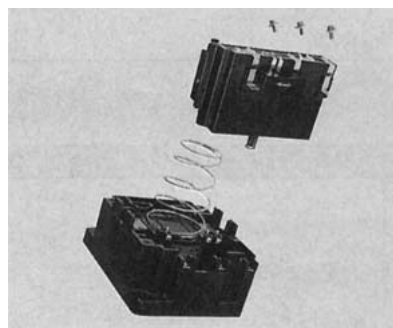

Ⓑ1) After removing Insulating cover, loose 3 screws of coil terminals.
 Ⓑ2) Remove control unit and return spring.

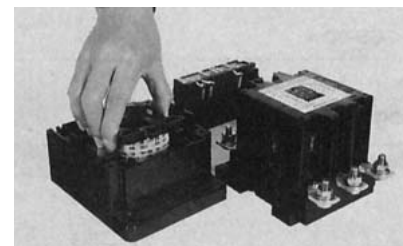

Ⓒ1) Replace to prescribed coil.
 Ⓒ2) Reassemble in order Ⓑ2)-Ⓑ1)-Ⓐ1)
 Ⓒ3) Control unit must be suit for replaced coil, and must be replaced with coil at the same time.
 Ⓒ4) Coil terminals for excepting 100/200V coil are Ⓒ1)-Ⓑ2).
 Ⓒ5) Secure transparent dustproof covers on both sides.

(Example 3) Case of H300C ~ H800C

Coil and control unit must be changed at the same time.

(A)

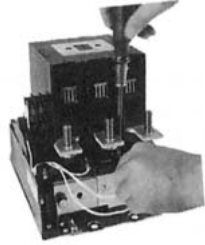

Remove the connecting wires (red, white, yellow) between coil and control unit.
Remove the control unit.

(B)

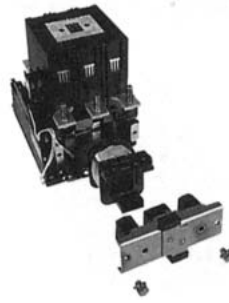

After loosening screws, remove the holding plate.
Remove the coil and replace to prescribed coil.

(C)

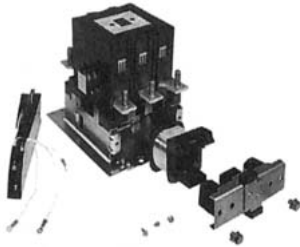

Replace the control unit which must be suit for the coil, at the same time of coil replacement.
Note: In case of H600C-R and H800C-R (Reversible type), mount the control unit of the contactor for forward on the left side.

(D)

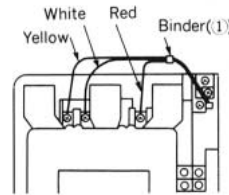

H300C, H400

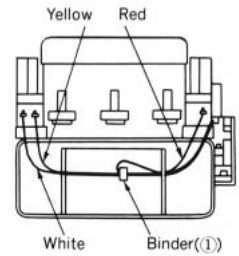

H600C, H800

Reconnect the wires (red, white, yellow) between coil and control unit.

Note: Bind the wires with the binder () packed with the control unit.

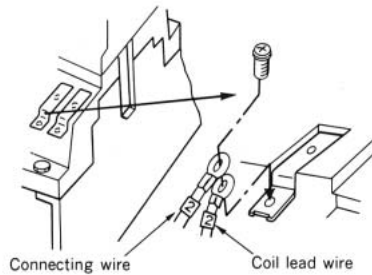

Note: In case of H600C, H800C, connecting wires and coil lead wires have the numbers (1, 2, and 3) at the end of wires.

Connect the wires of same number with the terminals.

(E)

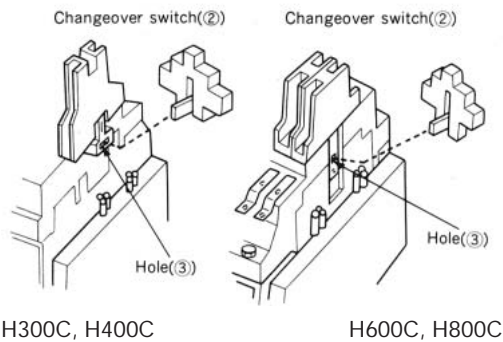

H300C, H400C

H600C, H800C

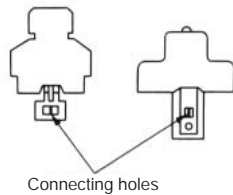

Connecting holes

(F)

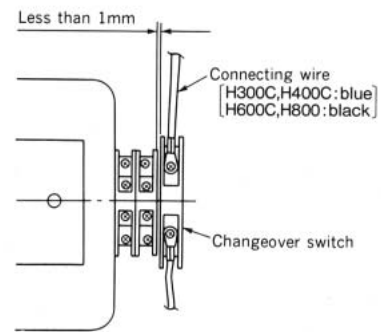

Connect the two blue wires (In case of H600C and H800C, black) with the terminals of changeover switch.

Note: After reassembling, adjust position of the control unit to make distance between the top of the changeover switch with the auxiliary contact unit closer than 1mm.

On mounting the changeover switch () on the control unit with screw, projection of movable portion on the changeover switch must be inserted to the hole of crossbar () for the auxiliary contact of contactor.

Caution: Insert the projection of the changeover switch to the correct hole of auxiliary contact unit

Note: 1. The changeover switches of H600C and H800C differ from H300C and 400C'S ones. (Their shapes are the same but parts in it are not the same.)
2. There is the white mark on the case of H600C and H800C's changeover switch, but no mark on H300C and H400C's one.

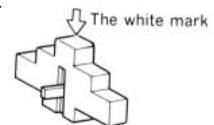

K-TYPE MANUAL STARTERS



SK2-TB

FEATURE

1. Small in Size and Light in Weight
Suitable as small-sized power switches for various kinds of industrial machines.
2. Easy Operation and Accurate Switching

Note

These are starters without motor protection device.

SPECIFICATIONS





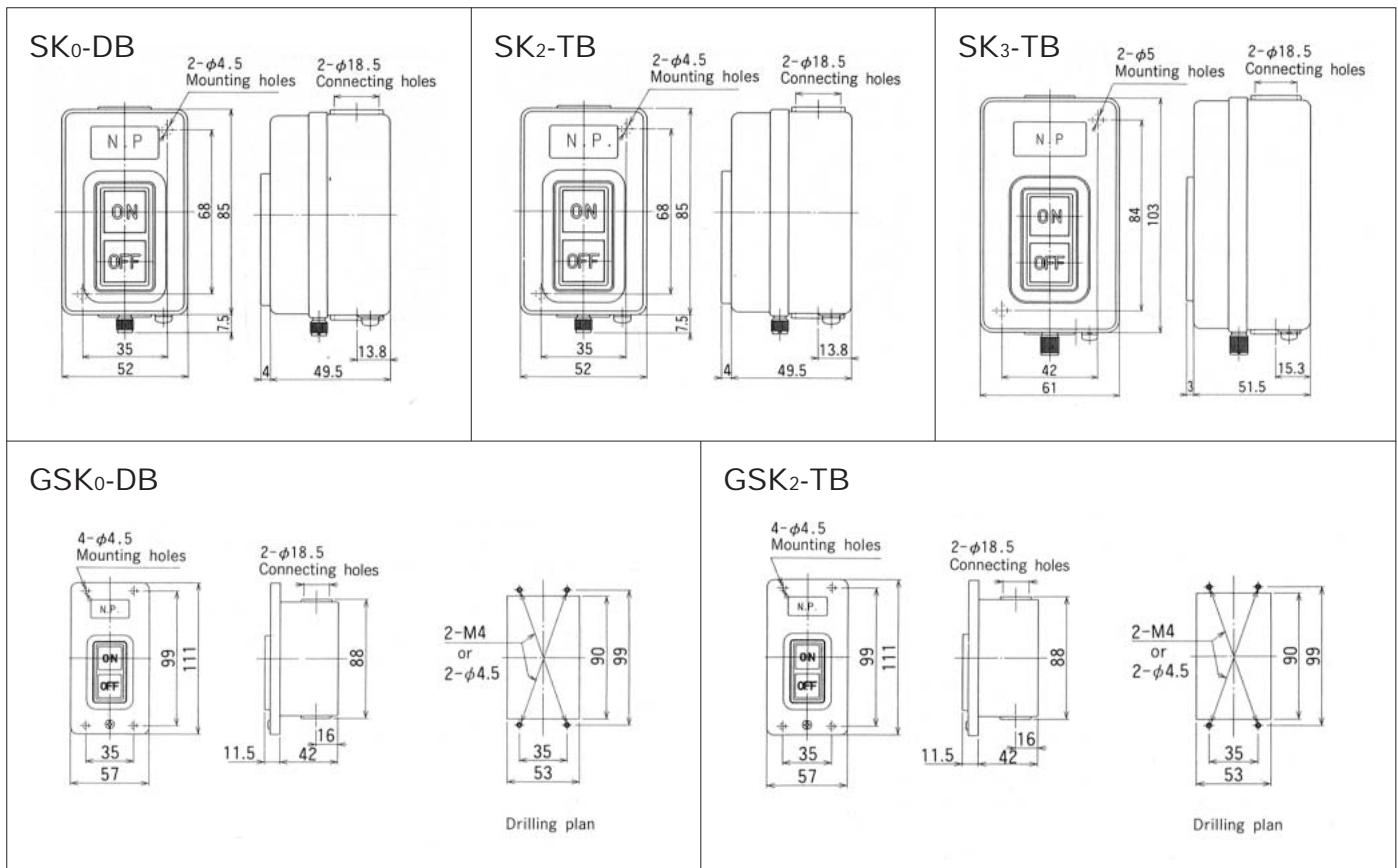





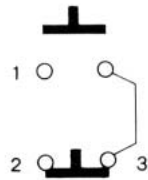

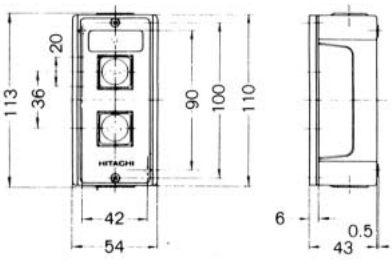
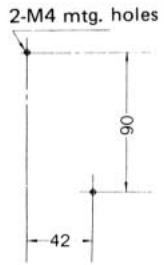

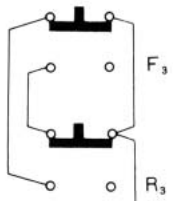
Type	No. of poles	Rated voltage (V)	Applicable motor capacity (HP) (kW)	Resistance load (A)	Mounting method	Weight (kg)
SK ₀ -DB	2	500	(1) 110V 0.4 (1/2) (1) 220V 1.1 (1 1/2)	15	surface mounting	0.19
GSK ₀ -DB					Flush mounting	0.22
SK ₂ -TB	3	500	220V 2.2 (3) 440V 2.2 (3)	15	surface mounting	0.19
GSK ₂ -TB					Flush mounting	0.22
SK ₃ -TB	3	500	220V 3.7 (5) 440V 3.7(5)	30	surface mounting	0.27

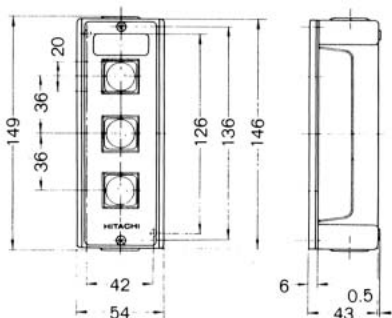
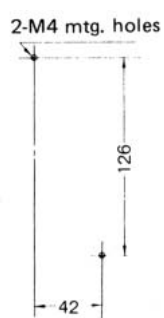
DIMENSIONS

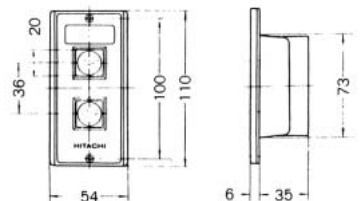
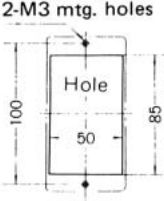

PUSH BUTTONS (FOR OPERATING OF MAGNETIC STARTERS AND CONTACTORS)

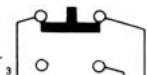
APPEARANCE, DIMENSIONS

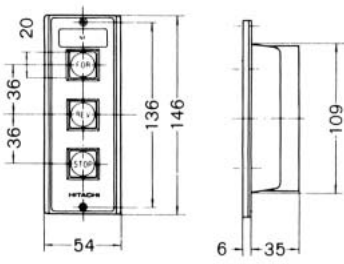
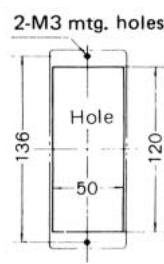
Appearance	Contact arrangement	Dimensions (mm)	Drilling plan
 <p>MB-2B</p>	<p>START</p>  <p>STOP</p> 		<p>2-M4 mtg. holes</p> 
 <p>MB-3B</p>	<p>FOR</p>  <p>REV</p>  <p>STOP</p> 		<p>2-M4 mtg. holes</p> 
 <p>GMB-2B</p>	<p>START</p>  <p>STOP</p> 		<p>2-M3 mtg. holes</p> 
 <p>GMB-3B</p>	<p>FOR</p>  <p>REV</p>  <p>STOP</p> 		<p>2-M3 mtg. holes</p> 

CONTACT RATINGS

Rated voltage (V)	Rated current (A)
220	3
440	1.5

LIFE

(million times)

Electrical	Mechanical
0.5	5

Specifications in this catalog are subject to change with or without notice, as Hitachi continues to develop the latest technologies and products for its customers.

 **Hitachi Industrial Equipment Systems Co., Ltd.**

For further information, please contact your nearest sales representative.